

Questions

Q1.

Answer the question with a cross in the box you think is correct . If you change your mind about an answer, put a line through the box and then mark your new answer with a cross .

Figure 1 shows a diagram of the heart.

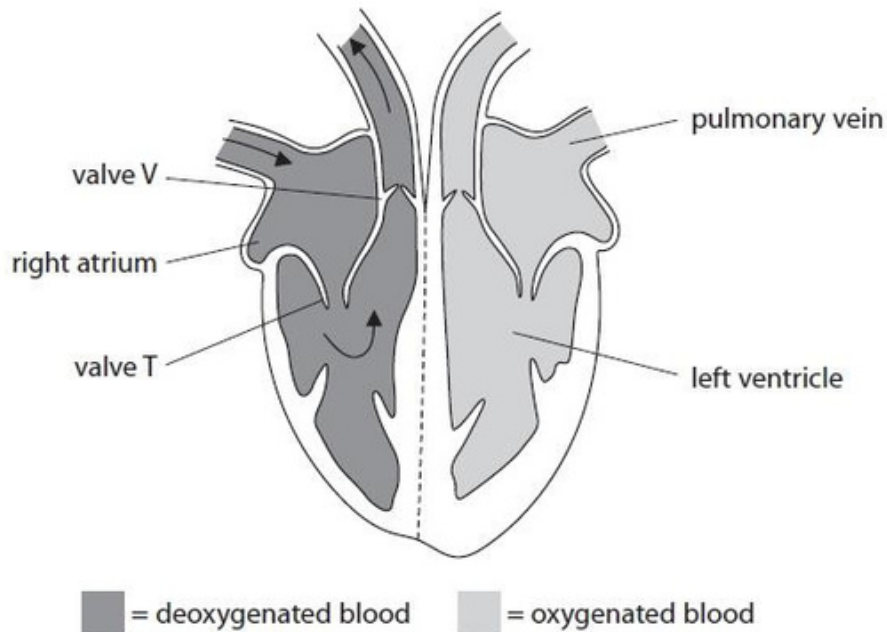

Figure 1

(i) Draw arrows on Figure 1 to show how oxygenated blood moves through the heart.

(1)

(ii) What happens when the right ventricle contracts?

(1)

- A valve T opens
- B valve T closes
- C blood is forced into the left atrium
- D blood is forced into the pulmonary vein

(iii) Draw one straight line from each structure to its function.

(2)

structure	function
pulmonary vein •	• carries deoxygenated blood
	• forces blood towards body organs
	• carries blood from the lungs to the heart
left ventricle •	• takes blood to the right side of the heart
	• forces blood towards the lungs

(Total for question = 4 marks)

Q2.

Figure 9 shows the structure and actual size of red blood cells (erythrocytes).

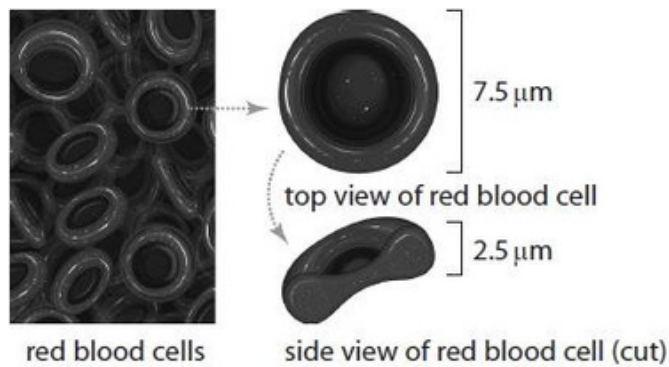

(Source: © N.Vinoth Narasingam/Shutterstock)

Figure 9

(i) Calculate the image size of the top view of this red blood cell if this cell is magnified 400 \times .

Give your answer in mm.

(2)

..... mm

(ii) Explain how the shape of a red blood cell is related to its function.

(3)

.....
.....
.....
.....
.....
.....

(iii) State the role of haemoglobin inside the red blood cell.

(1)

.....
.....

(Total for question = 6 marks)

Q3.

Figure 13 shows the heart rate of person A and person B.

Person A does not do any regular exercise.

Person B has been running regularly for one year.

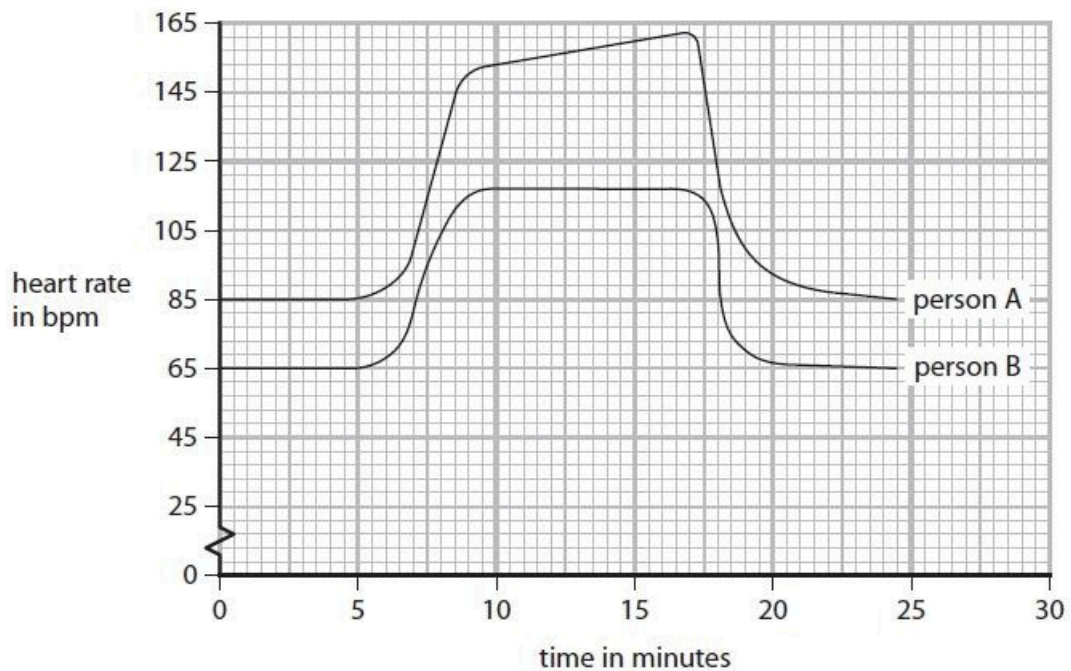

Figure 13

The stroke volume for person B before exercising was 61 ml per beat.

Calculate the cardiac output for person B before exercising.

Give your answer in litres per minute.

..... litres per minute

(Total for question = 3 marks)

Q4.

Figure 10 shows the estimated blood flow through some parts of the body when a person is at rest and during exercise.

part of the body	estimated rate of blood flow in cm ³ per minute	
	at rest	during exercise
brain	750	748
heart muscle	350	1 150
digestive system	2 500	1 200
other muscles	1 200	14 500
all other organs (except lungs)	1 423	1 420

Figure 10

A person has a cardiac output of 4.9 litres per minute. The stroke volume of each heart beat is 70 ml.

Calculate the heart rate.

(2)

..... beats per minute

(Total for question = 2 marks)

Q5.

Figure 9 shows the stroke volume at different heart rates of a person who has trained for a marathon and of a person who has not trained for a marathon.

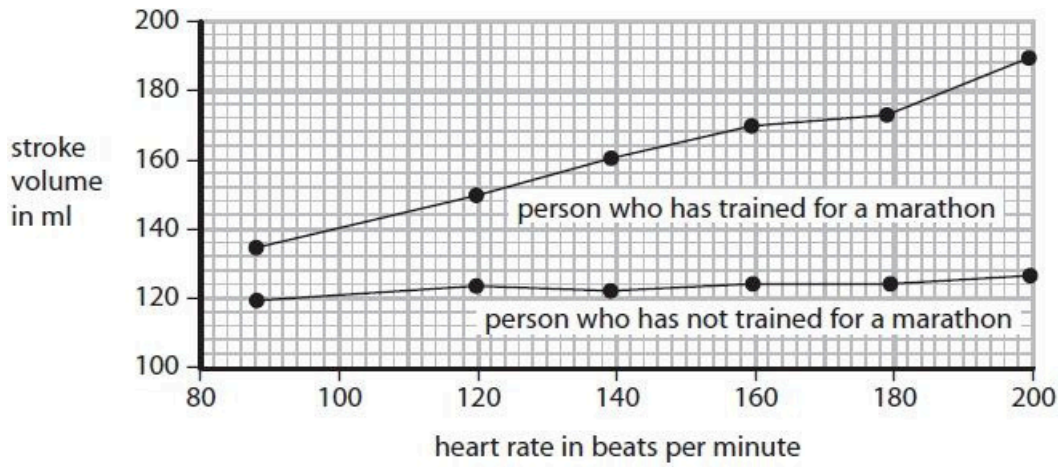

Figure 9

(i) Compare the effect of heart rate on stroke volume of the person who has trained for a marathon with the person who has not trained for a marathon.

(2)

.....

.....

.....

.....

.....

.....

(ii) Calculate the cardiac output for the person who has trained for a marathon when the heart rate is 160 beats per minute.

Give the units in your answer.

(3)

.....

(Total for question = 5 marks)

Q6.

Figure 13 shows the heart rate of person A and person B.

Person A does not do any regular exercise.

Person B has been running regularly for one year.

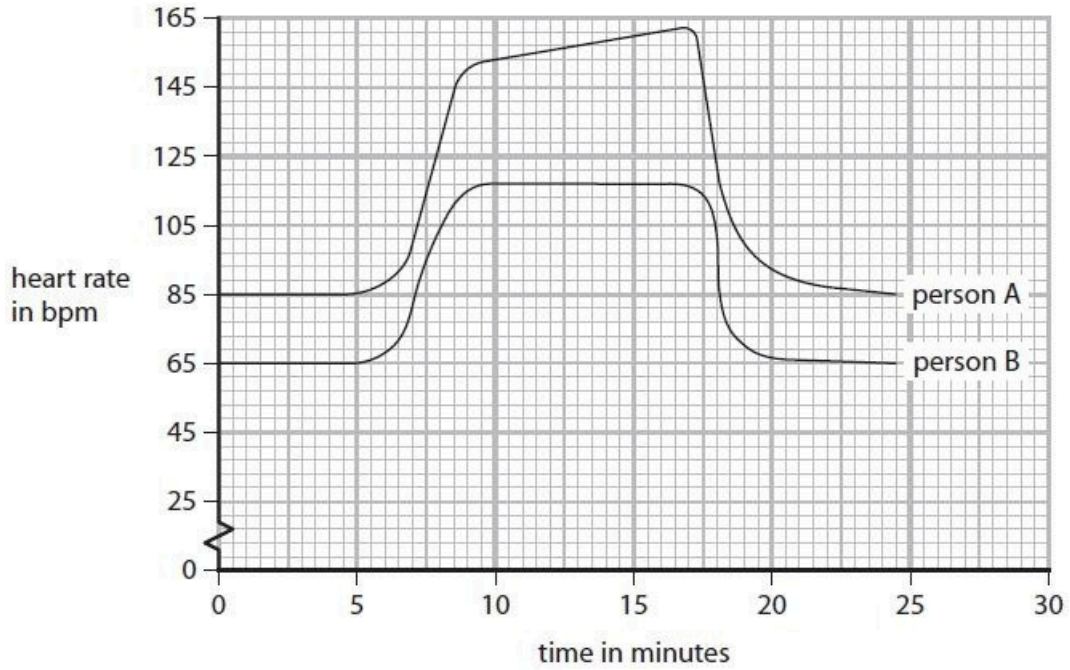

Figure 13

Both people rested for the first 6 minutes, then did the same high intensity exercise for the next 12 minutes, then rested.

Compare the heart rates of person A with the heart rates of person B.

.....

.....

.....

.....

.....

.....

.....

.....

.....

.....

(Total for question = 4 marks)

Q7.

Blood from the body enters the heart through the vena cava.

Describe how this blood flows through the heart and lungs to leave the heart through the aorta.

Include references to the chambers of the heart and the relevant valves in your answer.

(6)

.....

.....

.....

.....

.....

.....

.....

.....

.....

.....

.....

.....

.....

.....

.....

.....

.....

.....

.....

.....

.....

.....

(Total for question = 6 marks)

Q8.

Figure 11 shows the time taken for blood to clot at different temperatures.

temperature in °C	time taken for blood to clot in seconds
5	90
15	70
25	55
35	40
45	110

Figure 11

(i) Draw a graph to show the data in Figure 11.

(3)

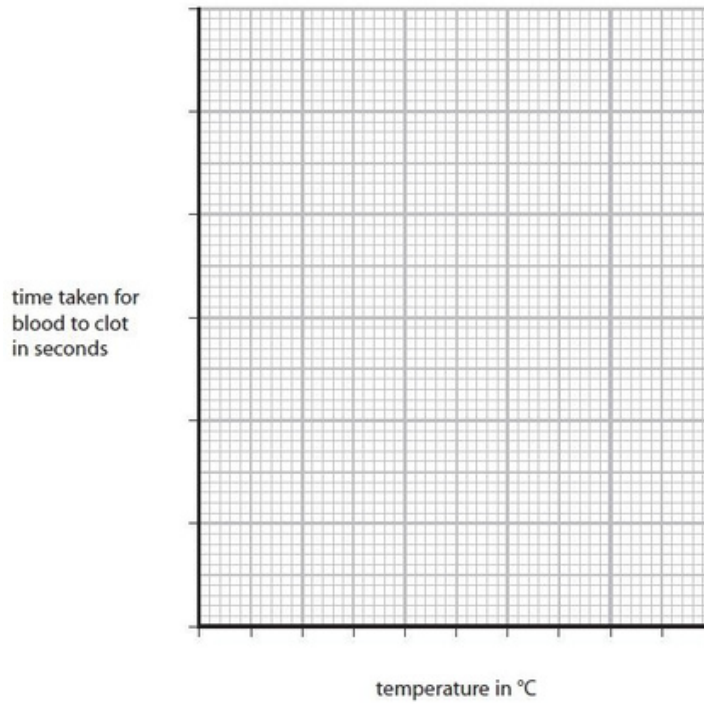

(ii) Give two safety precautions that should be used when handling blood samples.

(2)

- 1
-
- 2
-

(Total for question = 5 marks)

Q9.

Explain how one structure of a vein helps the blood return to the heart.

.....

.....

.....

.....

(Total for question = 2 marks)

Q10.

Figure 2 shows a dissected vein.

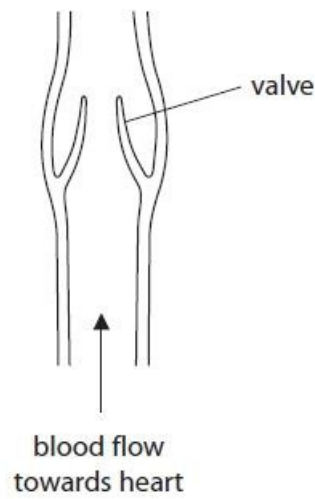

Figure 2

(i) Explain how the valves in veins help the blood, at low pressure, flow towards the heart.

(2)

.....

.....

.....

.....

(ii) The equipment used to dissect the vein was cleaned and put into disinfectant.

State why this equipment was put into disinfectant.

(1)

.....

.....

(Total for question = 3 marks)

Edexcel Biology GCSE - The Circulatory System

Q11.

Carbon dioxide is carried in blood plasma.

Human blood also contains red blood cells and white blood cells.

Explain how the structure of red blood cells and white blood cells is related to their function.

(6)

.....

.....

.....

.....

.....

.....

.....

.....

.....

.....

.....

.....

.....

.....

.....

.....

.....

.....

.....

.....

.....

.....

.....

.....

.....

(Total for question = 6 marks)

Q12.

* Figure 18 shows the structure of the human heart.

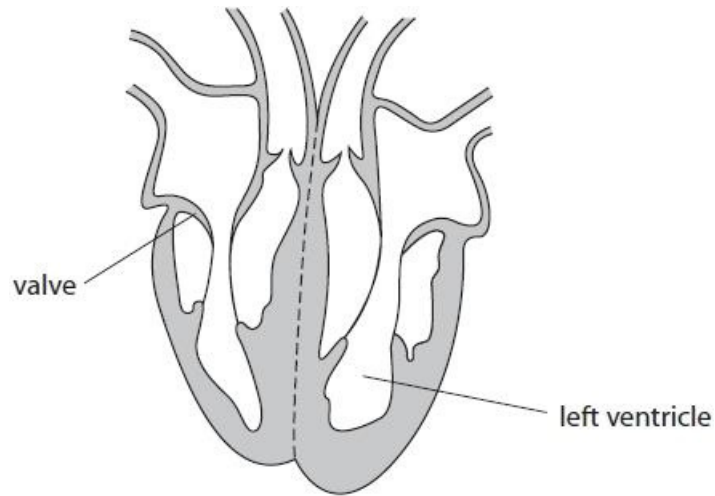

Figure 18

Explain how the structure of the heart is related to its function.

(6)

.....

.....

.....

.....

.....

.....

.....

.....

.....

.....

.....

.....

.....

.....

.....

(Total for question = 6 marks)

Q13.

Some blood transfusions contain red blood cells.

Red blood cells are stored in a solution containing 5.0% glucose and 0.9% salt.

Explain why red blood cells cannot be stored in pure water.

(3)

.....

.....

.....

.....

.....

.....

.....

.....

.....

.....

(Total for question = 3 marks)

Q14.

Figure 21 shows the circulatory system of a frog.

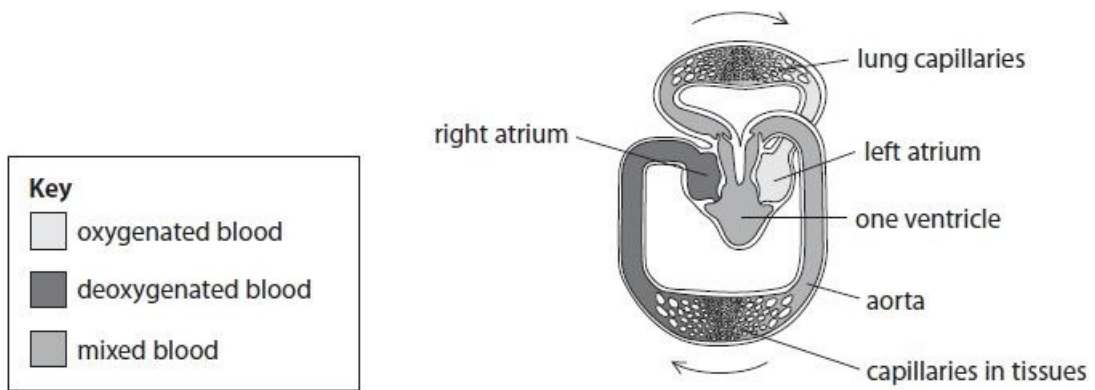

Figure 21

Explain why the circulatory system of a frog is less efficient at carrying oxygen to the tissues than the circulatory system of a human.

(3)

.....

.....

.....

.....

.....

.....

.....

.....

.....

.....

(Total for question = 3 marks)

Q15.

Figure 13 shows the heart rate of person A and person B.

Person A does not do any regular exercise.

Person B has been running regularly for one year.

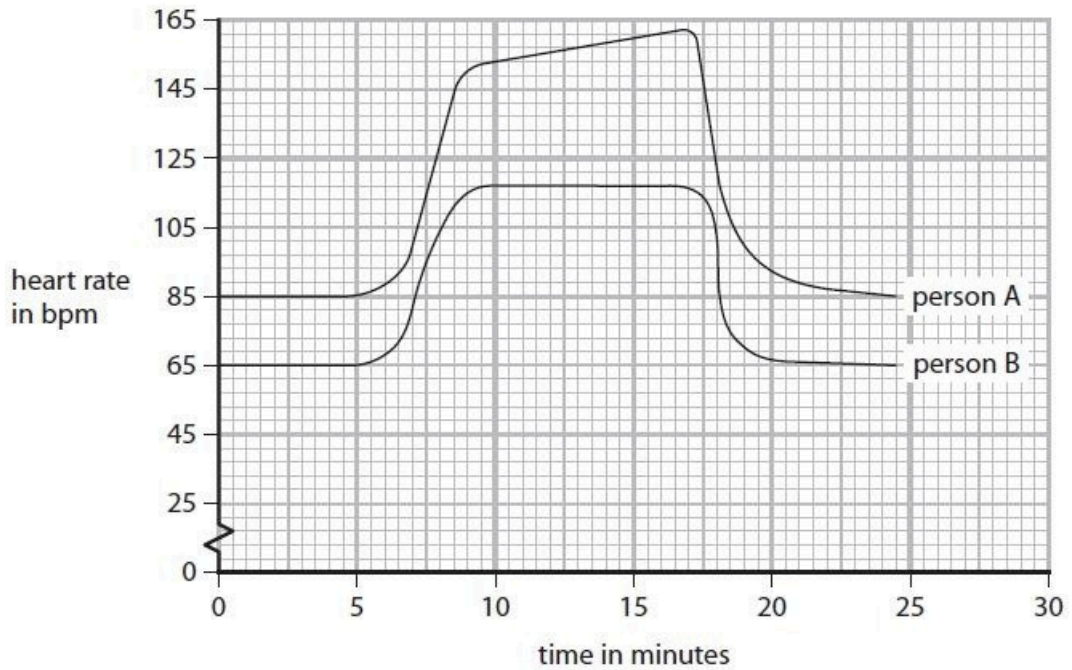

Figure 13

The cardiac output for person A during exercise was 5.5 litres per minute.

Explain why the heart rate for person A needed to be higher than the heart rate for person B during exercise.

.....

.....

.....

.....

.....

.....

.....

(Total for question = 3 marks)

Q16.

(i) Give a reason why veins have valves.

(1)

.....

(ii) Name the artery that transports oxygenated blood from the heart to the body.

(1)

.....

(Total for question = 2 marks)

Q17.

Figure 10 shows the estimated blood flow through some parts of the body when a person is at rest and during exercise.

part of the body	estimated rate of blood flow in cm ³ per minute	
	at rest	during exercise
brain	750	748
heart muscle	350	1 150
digestive system	2 500	1 200
other muscles	1 200	14 500
all other organs (except lungs)	1 423	1 420

Figure 10

The stroke volume is the amount of blood leaving one chamber of the heart per beat.

From which chamber of the heart does this volume of oxygenated blood flow?

(1)

- A left atrium
- B left ventricle
- C right atrium
- D right ventricle

(Total for question = 1 mark)

Edexcel Biology GCSE - The Circulatory System

Q18.

Insulin is produced by an endocrine gland and is transported in the blood.

(i) Which row shows the endocrine gland and the target organs for insulin?

(1)

	endocrine gland	target organs
<input type="checkbox"/> A	adrenal	liver and muscles
<input type="checkbox"/> B	adrenal	small and large intestines
<input type="checkbox"/> C	pancreas	liver and muscles
<input type="checkbox"/> D	pancreas	small and large intestines

(ii) Which part of the blood transports insulin to its target organs?

(1)

- A plasma
- B red blood cells
- C white blood cells
- D platelets

(Total for question = 2 marks)

Q19.

Answer the question with a cross in the box you think is correct . If you change your mind about an answer, put a line through the box and then mark your new answer with a cross .

(i) Which part of the blood causes blood to start clotting?

(1)

- A erythrocytes
- B lymphocytes
- C platelets
- D antibodies

(ii) Give one advantage of a blood clot forming.

(1)

.....
.....

(Total for question = 2 marks)

Q20.

Answer the question with a cross in the box you think is correct . If you change your mind about an answer, put a line through the box and then mark your new answer with a cross .

When skin is cut a blood clot forms.

Which part of the blood starts the clotting process?

- A red blood cells
- B water
- C platelets
- D white blood cells

(Total for question = 1 mark)

Q21.

Answer the question with a cross in the box you think is correct . If you change your mind about an answer, put a line through the box and then mark your new answer with a cross .

Figure 1 shows human blood seen using a light microscope.

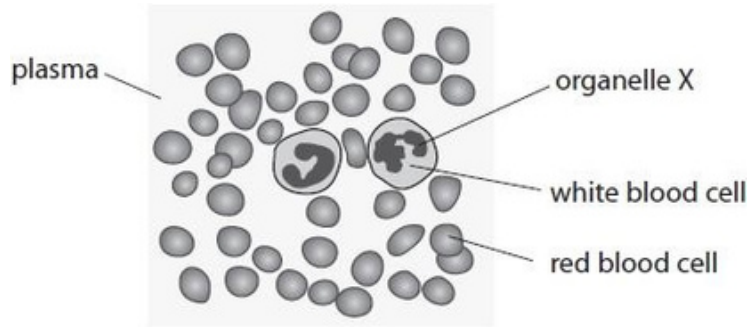

Figure 1

(i) The organelle labelled X controls the activities of the white blood cell.

What is the name of organelle X?

(1)

- A mitochondrion
- B ribosome
- C chromosome
- D nucleus

(ii) Use words from the box to complete the sentences.

(2)

gas	haemoglobin	hormone
liquid	platelet	solid

Red blood cells contain the substance

Blood plasma is a

(iii) Describe two ways that white blood cells protect the body from disease.

(2)

1

.....

2

.....

(Total for question = 5 marks)

Q22.

Figure 6 shows a cross section of an artery and a vein.

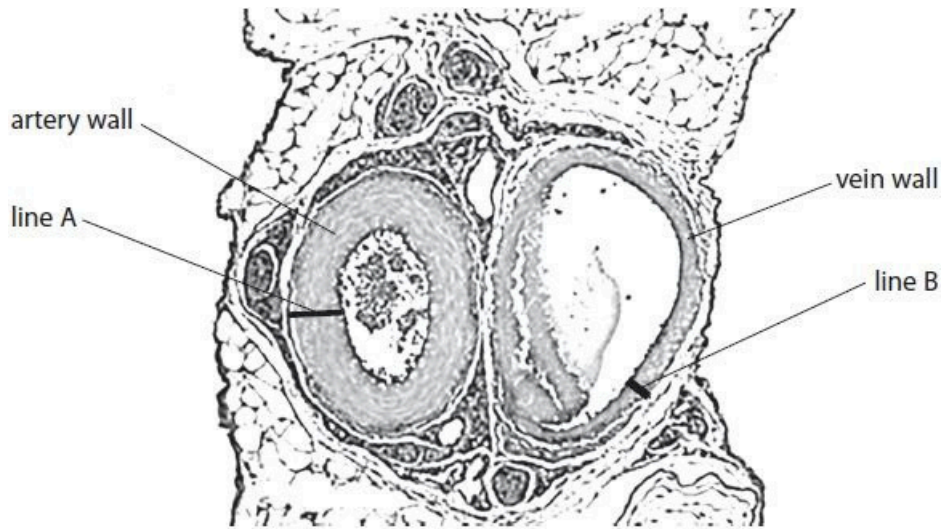

(Source: © The University of Kansas Medical Center)

Figure 6

(i) Measure the length of line A and the length of line B in mm.

(1)

line A mm line B
..... mm

(ii) State the ratio of the thickness of the artery wall to the thickness of the vein wall.

(1)

.....

(Total for question = 2 marks)

Q23.

Red blood cells are carried in veins and arteries.

Figure 20 shows the equipment used to measure the elasticity of an artery.

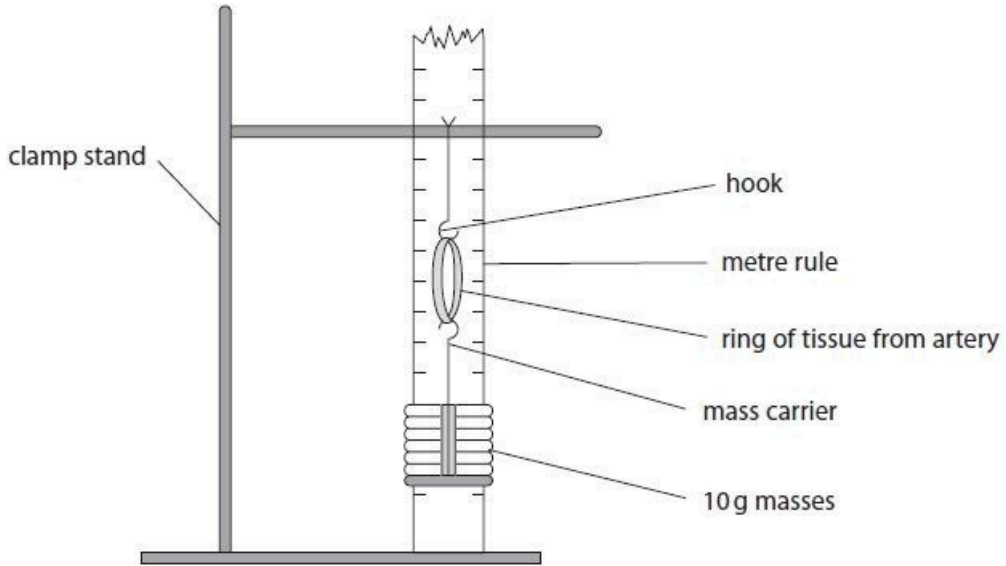

Figure 20

(i) Describe a method you could use to see how much the ring of tissue from an artery could stretch before it no longer returned to its original size.

(3)

.....

.....

.....

.....

.....

.....

(ii) Give one safety precaution you need to take when handling animal tissue such as blood vessels.

(1)

.....

.....

(Total for question = 4 marks)

Q24.

Figure 17 shows a cross-section of an artery and a vein.



(Source: © The University of Kansas Medical Center)

Figure 17

(i) Explain one difference between the artery wall and the vein wall shown in Figure 17.

(2)

.....

.....

.....

.....

.....

.....

(ii) Name one structure that is found in veins but not found in arteries.

(1)

.....

(Total for question = 3 marks)

Q25.

Blood contains red blood cells, white blood cells, plasma and platelets.

(i) Draw one straight line from each part of the blood to its function.

(2)

part of the blood	function
<div style="border: 1px solid black; padding: 2px; display: inline-block; margin-bottom: 10px;">plasma</div> <div style="border: 1px solid black; padding: 2px; display: inline-block;">red blood cell</div>	<div style="border: 1px solid black; padding: 2px; display: inline-block; margin-bottom: 10px;">• produces oestrogen</div> <div style="border: 1px solid black; padding: 2px; display: inline-block; margin-bottom: 10px;">• transports dissolved urea</div> <div style="border: 1px solid black; padding: 2px; display: inline-block; margin-bottom: 10px;">• contains haemoglobin</div> <div style="border: 1px solid black; padding: 2px; display: inline-block; margin-bottom: 10px;">• produces antibodies</div> <div style="border: 1px solid black; padding: 2px; display: inline-block;">• surrounds and digests foreign cells</div>

Figure 2 shows some red blood cells.

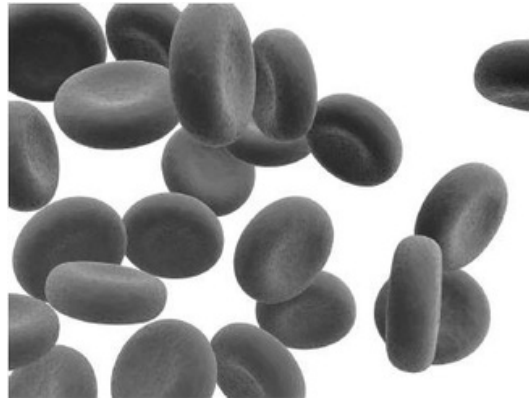

(Source: © SciePro/Shutterstock)

Figure 2

(ii) State two features that can be seen in the red blood cells in Figure 2.

(2)

- 1
-
- 2
-

(Total for question = 4 marks)

Q26.

The effect of different types of exercise on the heart rate of an athlete was investigated.

The athlete counted the number of beats in 10 seconds at the carotid artery pulse point, as shown in Figure 12.

This measurement was used to calculate the heart rate.

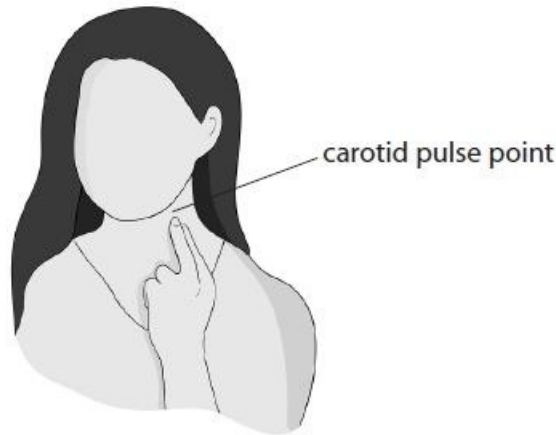

(Source: © dityazemli/Shutterstock)

Figure 12

The athlete exercised for 20 minutes.

The heart rate was recorded every 5 minutes during each type of exercise.

(i) State how the heart rate was calculated using this method.

(1)

.....
.....

(ii) Give two ways of improving the method used to obtain the data needed to calculate the heart rate.

(2)

1

.....

2

.....

Figure 13 shows the results of this investigation.

type of exercise	heart rate in bpm				
	0 minutes	5 minutes	10 minutes	15 minutes	20 minutes
running	90	156	168	180	180
walking	90	96	90	96	90

Figure 13

(iii) Comment on the difference in the heart rates during these types of exercise.

(3)

.....

.....

.....

.....

.....

.....

.....

.....

(Total for question = 6 marks)

Mark Scheme

Q1.

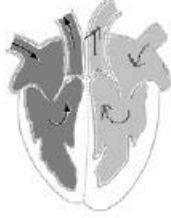
Question number	Answer	Additional guidance	Mark												
(i)	<p>All three arrows in correct direction (1)</p> 	accept any number of arrows showing the correct route	(1) AO1.1												
Question number	Answer		Mark												
(ii)	<p>B valve T closes</p> <p>The only correct answer is B valve T closes</p> <p>A is incorrect because valve T does not open.</p> <p>C is incorrect because blood is not forced into the left atrium.</p> <p>D is incorrect because blood is not forced into the pulmonary vein.</p>		(1) AO2.1												
Question number	Answer		Mark												
(iii)	<table border="0" style="width: 100%; border-collapse: collapse;"> <thead> <tr> <th style="text-align: left; width: 50%;">structure</th> <th style="text-align: left; width: 50%;">function</th> </tr> </thead> <tbody> <tr> <td></td> <td>● carries deoxygenated blood</td> </tr> <tr> <td>pulmonary vein</td> <td>● forces blood towards body organs</td> </tr> <tr> <td></td> <td>● carries blood from the lungs to the heart</td> </tr> <tr> <td>left ventricle</td> <td>● takes blood to the right side of the heart</td> </tr> <tr> <td></td> <td>● forces blood towards the lungs</td> </tr> </tbody> </table>	structure	function		● carries deoxygenated blood	pulmonary vein	● forces blood towards body organs		● carries blood from the lungs to the heart	left ventricle	● takes blood to the right side of the heart		● forces blood towards the lungs		(2) AO1.1
structure	function														
	● carries deoxygenated blood														
pulmonary vein	● forces blood towards body organs														
	● carries blood from the lungs to the heart														
left ventricle	● takes blood to the right side of the heart														
	● forces blood towards the lungs														
	Reject if more than one line is drawn from each structure.														

Edexcel Biology GCSE - The Circulatory System

Q2.

Question Number	Answer	Additional guidance	Mark
(i)	calculation $(7.5 \times 400 =) 3000$ (1) conversion $(3000 \div 1000 =) 3$ (mm)	ecf using 2.5 for 1 mark award full marks for correct answer with no working	(2) AO2 1

Question Number	Answer	Additional guidance	Mark
(ii)	An explanation linking: <ul style="list-style-type: none"> • the biconcave disc shape (1) • results in a larger surface area (1) • so (more) oxygen can be carried (1) 	accept description of biconcave disc accept (more) oxygen diffused	(3) AO1 1

Question Number	Answer	Additional guidance	Mark
(iii)	for oxygen to bind (inside the erythrocyte / red blood cell)	accept to carry oxygen	(1) AO1 1

Edexcel Biology GCSE - The Circulatory System

Q3.

Question number	Answer	Additional guidance	Mark
	Substitution: 65×61 (1) Evaluation: $= 3\,965$ (1) Conversion: $3\,965 \div 1000 = 3.965$ (litres per minute)	Full marks for correct answer no working Conversion $61 \div 1000$ (1) 0.061×65 for substitution mark With $3.965/4$ for evaluation mark Accept 4 or any other correct rounding	(3) A02.1

Q4.

Question number	Answer	Additional guidance	Mark
	Substitution $4.9 \div 0.07$ / $4\,900 \div 70$ (1) Evaluation 70 (beats per minute)	full marks for correct answer no working accept $4.9 \div 70 = 0.07$ for 1 mark	(2) AO 1 2

Edexcel Biology GCSE - The Circulatory System

Q5.

Question number	Answer	Additional guidance	Mark
(i)	<p>An answer comparing two from:</p> <ul style="list-style-type: none"> the stroke volume of the person who has trained for the marathon is (always) higher / ORA (1) as heart rate increases for the person who has trained for the marathon stroke volume increases (1) as heart rate increases for the person who has not trained for the marathon the stroke volume {stays constant/only increases slightly} (1) 	accept comparative data	(2) AO3 2ab

Question number	Answer	Additional guidance	Mark
(ii)	<p>cardiac output = heart rate x stroke volume (1)</p> <p>Substitution 160 x 170 = 27 200 (1)</p> <p>unit ml per min/ ml.min⁻¹</p>	<p>accept correct calculation for 2 marks as equation is implied.</p> <p>accept range for stroke volume of 168 -172</p> <p>accept 27.2 L.min⁻¹ / 27.2 dm³.min⁻¹ for 3 marks</p>	(3) AO1 1

Q6.

Question number	Answer	Additional guidance	Mark
	<p>An answer comparing the following:</p> <ul style="list-style-type: none"> • the heart rate of person A is higher than the heart rate of person B (1) • the heart rate of person A increases more during exercise than person B (1) • the heart rate of person B is level during exercise whereas the heart rate of person A keeps increasing (1) • person B returns to their resting heart rate faster than person A (1) • comparative data analysis (1) 	<p>accept the rate of increase for person A is higher than person B</p>	<p>(4)</p> <p>A03 1ab</p>

Q7.

Question number	Indicative content	Mark
*	<p>Answers will be credited according to candidate's deployment of knowledge and understanding of the material in relation to the qualities and skills outlined in the generic mark scheme. The indicative content below is not prescriptive, and candidates are not required to include all the material that is indicated as relevant. Additional content included in the response must be scientific and relevant.</p> <p style="text-align: center;">AO1 (6 marks)</p> <ul style="list-style-type: none"> • Blood flows from vena cava into the right atrium • Into the right ventricle • Through valve • And is pumped into the pulmonary artery • Through valve to the lungs • From the lungs back to the heart through the pulmonary vein • Into the left atrium • Into the left ventricle • Through valve • And is pumped into the aorta • Through valve • valves prevent backflow 	(6) AO1 1

Level	Descriptor
	No rewardable material.
Level 1	<ul style="list-style-type: none"> • Demonstrates elements of biological understanding, some of which is inaccurate. Understanding of scientific ideas lacks detail. • Presents an explanation with some structure and coherence.
Level 2	<ul style="list-style-type: none"> • Demonstrates biological understanding, which is mostly relevant but may include some inaccuracies. Understanding of scientific ideas is not fully detailed and/or developed. • Presents an explanation that has a structure which is mostly clear, coherent and logical.
Level 3	<ul style="list-style-type: none"> • Demonstrates accurate and relevant biological understanding throughout. Understanding of the scientific ideas is detailed and fully developed. • Presents an explanation that has a well-developed structure which is clear, coherent and logical.

Edexcel Biology GCSE - The Circulatory System

Q8.

Question number	Answer	Additional guidance	Mark
(i)	<p>Linear scale on both axis (1)</p> <p>Plotted points (1)</p> <p>Correctly drawn graph (1)</p>	<p>Accept accurate plotting to ½ small square</p> <p>Accept dot to dot drawing or a freehand single line linking points</p>	<p>(3)</p> <p>A02.1</p>

Question number	Answer	Additional guidance	Mark
(ii)	<p>An answer including two of the following:</p> <ul style="list-style-type: none"> • wear gloves (1) • wash hands after handling (1) • sterilise equipment after use / use sterile equipment / keep it in a sealed container (1) 	<p>accept cover {open wounds/cuts}</p>	<p>(2)</p> <p>A031ab</p>

Q9.

Question number	Answer	Additional guidance	Mark
	<p>An answer linking two of the following:</p> <ul style="list-style-type: none"> • veins contain valves (1) • which prevent the backflow of blood (1) <p>OR</p> <ul style="list-style-type: none"> • veins have a large lumen (1) • to maximise blood flow (1) 	<p>accept keep blood flowing in one direction</p> <p>accept to carry a lot of blood</p>	<p>(2)</p> <p>A01 1</p>

Q10.

Question number	Answer	Mark
(i)	An explanation linking the following: <ul style="list-style-type: none"> • the valve closes (1) • (therefore) it prevents backflow (1) 	(2) AO2.1

Question number	Answer	Additional guidance	Mark
(ii)	To kill bacteria / pathogens / microorganisms /	accept to sterilise equipment ignore disinfect / clean equipment	(1) A01.2

Q11.

Question number	Indicative content	Mark		
<p style="text-align: center;">*</p>	<p>Answers will be credited according to candidate's deployment of knowledge and understanding of the material in relation to the qualities and skills outlined in the generic mark scheme.</p> <p>The indicative content below is not prescriptive and candidates are not required to include all the material that is indicated as relevant. Additional content included in the response must be scientific and relevant.</p> <p style="text-align: center;">AO1 (marks)</p> <p>Red blood cells</p> <table border="0" style="width: 100%;"> <tr> <td style="width: 50%; vertical-align: top;"> <p><u>structure</u></p> <ul style="list-style-type: none"> • contains haemoglobin • biconcave disc shaped • small / flexible / smooth • no nucleus </td> <td style="width: 50%; vertical-align: top;"> <p><u>function</u></p> <ul style="list-style-type: none"> • to carry oxygen • oxygen is joined to haemoglobin. • to increase surface area / to absorb / to release oxygen quicker • so can fit through capillaries • so can contain more haemoglobin </td> </tr> </table>	<p><u>structure</u></p> <ul style="list-style-type: none"> • contains haemoglobin • biconcave disc shaped • small / flexible / smooth • no nucleus 	<p><u>function</u></p> <ul style="list-style-type: none"> • to carry oxygen • oxygen is joined to haemoglobin. • to increase surface area / to absorb / to release oxygen quicker • so can fit through capillaries • so can contain more haemoglobin 	<p>(6)</p> <p>A01.1</p>
<p><u>structure</u></p> <ul style="list-style-type: none"> • contains haemoglobin • biconcave disc shaped • small / flexible / smooth • no nucleus 	<p><u>function</u></p> <ul style="list-style-type: none"> • to carry oxygen • oxygen is joined to haemoglobin. • to increase surface area / to absorb / to release oxygen quicker • so can fit through capillaries • so can contain more haemoglobin 			
	<p>White blood cells</p> <table border="0" style="width: 100%;"> <tr> <td style="width: 50%; vertical-align: top;"> <p><u>structure</u></p> <ul style="list-style-type: none"> • has receptors on membrane • are large cells /can change shape / have flexible membranes • has a nucleus / ribosomes </td> <td style="width: 50%; vertical-align: top;"> <p><u>function</u></p> <ul style="list-style-type: none"> • is part of the immune system / fights disease • can recognise pathogens / antigens • can engulf pathogens • makes antibodies / antitoxins / remember antigens from a previous infection </td> </tr> </table>	<p><u>structure</u></p> <ul style="list-style-type: none"> • has receptors on membrane • are large cells /can change shape / have flexible membranes • has a nucleus / ribosomes 	<p><u>function</u></p> <ul style="list-style-type: none"> • is part of the immune system / fights disease • can recognise pathogens / antigens • can engulf pathogens • makes antibodies / antitoxins / remember antigens from a previous infection 	
<p><u>structure</u></p> <ul style="list-style-type: none"> • has receptors on membrane • are large cells /can change shape / have flexible membranes • has a nucleus / ribosomes 	<p><u>function</u></p> <ul style="list-style-type: none"> • is part of the immune system / fights disease • can recognise pathogens / antigens • can engulf pathogens • makes antibodies / antitoxins / remember antigens from a previous infection 			

Edexcel Biology GCSE - The Circulatory System

Level	Mark	
	0	No rewardable material.
Level 1	1-2	Demonstrates elements of biological understanding, some of which is inaccurate. Understanding of scientific ideas lacks detail. Presents an explanation with some structure and coherence.
Level 2	3-4	Demonstrates biological understanding, which is mostly relevant but may include some inaccuracies. Understanding of scientific ideas is not fully detailed and/or developed. Presents an explanation that has a structure which is mostly clear, coherent and logical.
Level 3	5-6	Demonstrates accurate and relevant biological understanding throughout. Understanding of the scientific ideas is detailed and fully developed. Presents an explanation that has a well-developed structure which is clear, coherent and logical.

Q12.

Question Number	Indicative content	Mark
*	<p>Functions linked to structures</p> <ul style="list-style-type: none"> • walls contract / the heart pumps blood • atria push blood down into the ventricles • ventricles pumps blood out of heart • left ventricle / side pumps {blood to the body / oxygenated blood} • right ventricle/ side pumps {blood to the lungs / deoxygenated blood} • left ventricle wall thicker (than right ventricle wall) / produces more pressure to pump blood • right ventricle is thinner / produces less pressure to pump blood • valves prevent backflow /named valves prevent backflow between specific parts of the heart • the muscles can contract faster / harder so that blood is pushed around the body faster • the septum stops (oxygenated blood mixing with deoxygenated blood) • named arteries / veins related to where blood is going to / coming from 	<p>(6) AO1 1</p>

Edexcel Biology GCSE - The Circulatory System

Level	Mark	Descriptor
	0	<ul style="list-style-type: none"> No rewardable material.
Level 1	1-2	<ul style="list-style-type: none"> Demonstrates elements of biological understanding, some of which is inaccurate. Understanding of scientific ideas lacks detail. Presents an explanation with some structure and coherence.
Level 2	3-4	<ul style="list-style-type: none"> Demonstrates biological understanding, which is mostly relevant but may include some inaccuracies. Understanding of scientific ideas is not fully detailed and /or developed. Presents an explanation that has a structure which is mostly clear, coherent and logical.
Level 3	5-6	<ul style="list-style-type: none"> Demonstrates accurate and relevant biological understanding throughout. Understanding of the scientific ideas is detailed and fully developed. Presents an explanation that has a well-developed structure which is clear, coherent and logical.

Level	Mark	Additional Guidance	General additional guidance
	0	No rewardable material	<p>The level is determined by the functions covered in the response The mark within the level is determined by linking the functions to their related structures</p> <p><u>Possible candidate responses</u></p>
Level 1	1-2	<ul style="list-style-type: none"> An isolated function is identified the function is linked to a relevant structure 	<ul style="list-style-type: none"> the heart pumps blood around the body the heart pumps blood around the body when the muscles contract.
Level 2	3-4	<ul style="list-style-type: none"> more than one function is identified the functions are linked to their relevant structures 	<ul style="list-style-type: none"> when the heart contracts, blood is forced into the arteries. The blood on the left side does not mix with the blood on the right side. the left ventricle has thicker walls that push blood out through the aorta to the body under high pressure.
Level 3	5-6	<ul style="list-style-type: none"> at least three functions are identified the functions are linked to their relevant structures 	<ul style="list-style-type: none"> the atria push the blood into the ventricles. This can only go this way blood can't go back up into the atria. When the ventricles contract the left walls are thicker than the right so put the blood under more pressure. The two sides are separated by a wall of muscle which stops the oxygenated and the deoxygenated blood mixing. Blood flows back to the heart in veins. This flows into the atria which contract pushing blood into the ventricles.

Edexcel Biology GCSE - The Circulatory System

Q13.

Question Number	Answer	Additional guidance	Mark
	<p>An explanation linking three from:</p> <ul style="list-style-type: none"> • water will move into the erythrocyte (1) • by osmosis (1) • down a concentration gradient (1) • causing the erythrocyte to {burst/lyse} (1) 	<p>accept red blood cell for erythrocyte</p> <p>accept from high water concentration to low water concentration</p>	<p>(3)</p> <p>AO2 1</p>

Q14.

Question number	Answer	Additional guidance	Mark
	<p>An explanation including any three from:</p> <ul style="list-style-type: none"> • (frogs) have one ventricle / three chambers (1) • (whereas) humans have two ventricles/ four chambers (1) • no wall / septum separating ventricles (1) • oxygenated and deoxygenated blood mix (in the ventricle / heart) (1) 	<p>accept some blood going to the lungs is already oxygenated (1)</p>	<p>(3)</p> <p>AO 2 1</p>

Edexcel Biology GCSE - The Circulatory System

Q15.

Question number	Answer	Additional guidance	Mark
	<p>An answer linking the following:</p> <ul style="list-style-type: none"> • person A had a lower stroke volume (1) • pumps less blood out per beat (1) • so needed to have a higher heart rate to get a similar cardiac output (1) • in order to exercise at the same intensity (1) • to supply oxygen/glucose to the muscles (1) 	accept the heart is not used to exercise	<p>(3)</p> <p>A03.2ab</p>

Q16.

Question number	Answer	Mark
(i)	<ul style="list-style-type: none"> • to stop backflow of blood / to ensure blood flows in {one direction /right direction/towards the heart} / because the blood pressure in them is (too) low . 	<p>(1)</p> <p>AO1.1</p>
(ii)	<p>(the) aorta</p> <p>accept phonetic spellings. Do not award if spelling is closer to artery than aorta.</p>	<p>(1)</p> <p>AO1.1</p>

Edexcel Biology GCSE - The Circulatory System

Q17.

Question number	Answer	Mark
	<p>B left ventricle</p> <p>1. The only correct answer is B</p> <p><i>A is not correct because the left atrium receives blood from the pulmonary vein</i></p> <p><i>C is not correct because The right atrium receives blood from the vena cava</i></p> <p><i>D is not correct because the right ventricle has deoxygenated blood</i></p>	<p>(1)</p> <p>AO 1 1</p>

Q18.

Question number	Answer	Mark
(i)	<p>C pancreas liver and muscles</p> <p>1. The only correct answer is C</p> <p><i>A is not correct because the adrenal glands do not produce insulin</i></p> <p><i>B is not correct because the adrenal glands do not produce insulin and the small and large intestines are not the target organs for insulin</i></p> <p><i>D is not correct because the small and large intestines are not the target organs for insulin</i></p>	<p>(1)</p> <p>AO 1 1</p>

Question number	Answer	Mark
(ii)	<p>A plasma</p> <p>1. The only correct answer is A</p> <p><i>B is not correct because red blood cells do not transport insulin</i></p> <p><i>C is not correct because white blood cells do not transport insulin</i></p> <p><i>D is not correct because platelets do not transport insulin</i></p>	<p>(1)</p> <p>AO 1 1</p>

Edexcel Biology GCSE - The Circulatory System

Q19.

Question number	Answer	Mark
(i)	<p>C platelets</p> <p>The only correct answer is C platelets</p> <p>A is incorrect because erythrocytes are red blood cells which carry oxygen</p> <p>B is incorrect because lymphocytes are white blood cells which are part of the immune system</p> <p>D is incorrect because antibodies are part of the immune response</p>	<p>(1)</p> <p>A01 1</p>

Question number	Answer	Additional guidance	Mark
(ii)	to stop blood loss / prevent bacteria entering / stops bleeding (1)	Accept microorganisms/pathogen/virus for bacteria	<p>(1)</p> <p>A02 1</p>

Q20.

Question number	Answer	Mark
	<p>C platelets</p> <p>The only correct answer is C platelets</p> <p>A is incorrect because red blood cells do not start the clotting process.</p> <p>B is incorrect because water does not start the clotting process.</p> <p>D is incorrect because white blood cells do not start the clotting process.</p>	<p>(1)</p> <p>A01.1</p>

Edexcel Biology GCSE - The Circulatory System

Q21.

Question Number	Answer	Mark
(i)	<p>D nucleus</p> <p>The only correct answer is D</p> <p><i>A is not correct because mitochondria do not control the white blood cell</i></p> <p><i>B is not correct because ribosomes do not control the white blood cell</i></p> <p><i>C is not correct because chromosomes are only part of organelle X</i></p>	<p>(1)</p> <p>AO1.1a</p>

Question Number	Answer	Additional guidance	Mark
(ii)	<p>haemoglobin (1)</p> <p>liquid (1)</p>	<p>answers must be in correct order</p>	<p>(2)</p> <p>AO2.1</p>

Question Number	Answer	Additional guidance	Mark
(iii)	<p>A description including two from:</p> <ul style="list-style-type: none"> • make antibodies • {surround / engulf / digest} {pathogens / bacteria / viruses} • remembers pathogens / bacteria / viruses (so can react quickly to secondary infection) 	<p>accept produce memory cells</p>	<p>(2)</p> <p>AO1.1</p>

Q22.

Question number	Answer	Additional guidance	Mark
(i)	<p>line A = 8(mm) line B = 4(mm)</p> <p>The below measurements are an accepted answer for modified papers.</p> <p>The letter pre-fixing the log number denotes the size.</p> <p>A4 18pt X56407 A 8mm B 4mm</p> <p>A4 24pt Y56407 A 8mm B 4mm</p> <p>A3 24pt Q56407 A 12mm B 6mm</p> <p>A3 36pt V56407 A 12mm B 6mm</p>	accept ± 0.5 mm for both measurements.	(1) A02.2
(ii)	2:1 (1)	accept 8:4 / 4:2 ecf: accept a ratio of candidate's measurements of line A to line B from i	(1) A02.1

Edexcel Biology GCSE - The Circulatory System

Q23.

Question number	Answer	Additional guidance	Mark
(i)	<p>An answer that combines three of the following points to provide a method:</p> <ul style="list-style-type: none"> • measure the length of the tissue (1) • add masses / mass (1) • remove the mass and measure length of the tissue (1) • repeat until the tissue no longer returns to its original length (1) 	accept remove the mass and see if the tissue returns to its original size	(3) AO 3 3a

Question number	Answer	Additional guidance	Mark
(ii)	<p>Any one from:</p> <ul style="list-style-type: none"> • wash hands (1) • wear gloves (1) • sterilise the apparatus after use / disinfect working area (1) 	ignore standard lab rules accept cover open wounds	(1) AO 2 2

Q24.

Question Number	Answer	Additional guidance	Mark
(i)	<p>An explanation linking:</p> <ul style="list-style-type: none"> • artery has a {thicker / more muscular} wall (1) • because of the (blood) pressure (higher in artery than in vein) (1) 	accept prevent the artery bursting / maintain blood pressure	(2) AO2 1

Edexcel Biology GCSE - The Circulatory System

Question Number	Answer		Mark
(ii)	valve/valves		(1) AO1 1

Q25.

Question Number	Answer	Mark
(i)	<div style="display: flex; justify-content: space-between;"> <div style="width: 45%;"> <p>part of the blood</p> <div style="margin-top: 20px;"> <div style="border: 1px solid black; padding: 2px; width: 100px; margin-bottom: 10px;">plasma</div> <div style="border: 1px solid black; padding: 2px; width: 100px; margin-bottom: 10px;">red blood cell</div> </div> </div> <div style="width: 45%;"> <p>function</p> <div style="margin-top: 20px;"> <div style="border: 1px solid black; padding: 2px; width: 100%; margin-bottom: 5px;">• produces oestrogen</div> <div style="border: 1px solid black; padding: 2px; width: 100%; margin-bottom: 5px;">• transports dissolved urea</div> <div style="border: 1px solid black; padding: 2px; width: 100%; margin-bottom: 5px;">• contains haemoglobin</div> <div style="border: 1px solid black; padding: 2px; width: 100%; margin-bottom: 5px;">• produces antibodies</div> <div style="border: 1px solid black; padding: 2px; width: 100%;">• surrounds and digests foreign cells</div> </div> </div> </div>	(2) AO1 1

Question Number	Answer	Mark
(ii)	<p>Any two from:</p> <ul style="list-style-type: none"> • round (1) • disc shaped (1) • biconcave / dimple / indented on each side / large surface area (1) • smooth (1) 	(2) AO2 1

Q26.

Question Number	Answer	Additional Guidance	Mark
(i)	multiply the number of beats (in 10 seconds) by 6	accept times by six	(1) AO2

Question Number	Answer	Additional Guidance	Mark
(ii)	<p>Any two from:</p> <ul style="list-style-type: none"> • use a heart rate monitor / electronic device (to measure HR) (1) • take readings more frequently than 5 minutes (1) • record the pulse for longer than 10 seconds (1) • take repeat readings / calculate a mean (1) 	<p>ignore use a stopwatch</p> <p>accept repeat it</p>	(2) AO3b

Edexcel Biology GCSE - The Circulatory System

Question Number	Answer	Additional Guidance	Mark
(iii)	<p>An answer linking three from:</p> <ul style="list-style-type: none">heart rate {remains relatively constant / fluctuates slightly} when walking (1)heart rate increases when running (1)heart rate levels off {at 15 minutes / at 180 b.p.m.} when running (1)	<p>accept heart rate stays at 90 b.p.m. to 96 b.p.m. when walking</p> <p>accept heart rate is higher when running / data illustrating the difference</p>	(3) A03