

Questions are for both separate science and combined science students
unless indicated in the question

1.

A student investigated how the current in a series circuit varied with the resistance of a variable resistor.

Figure 1 shows the circuit used.

Figure 1

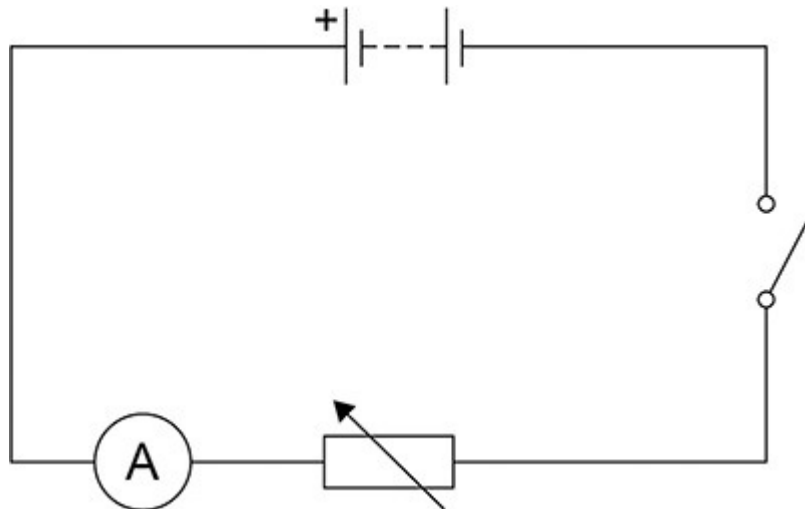
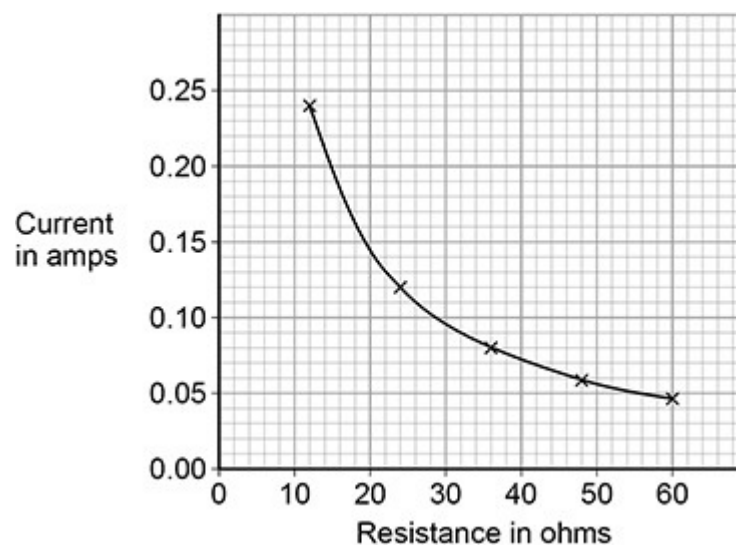

Figure 2 shows the results.

Figure 2



- (a) The battery had a power output of 230 mW when the resistance of the variable resistor was 36 Ω .

Determine the potential difference across the battery.

Potential difference = _____ V

(4)

- (b) The student concluded:
‘the current in the circuit was inversely proportional to the resistance of the variable resistor.’

Explain how **Figure 2** shows that the student is correct.

(2)

(c) **Figure 3** shows a circuit with a switch connected incorrectly.

Figure 3

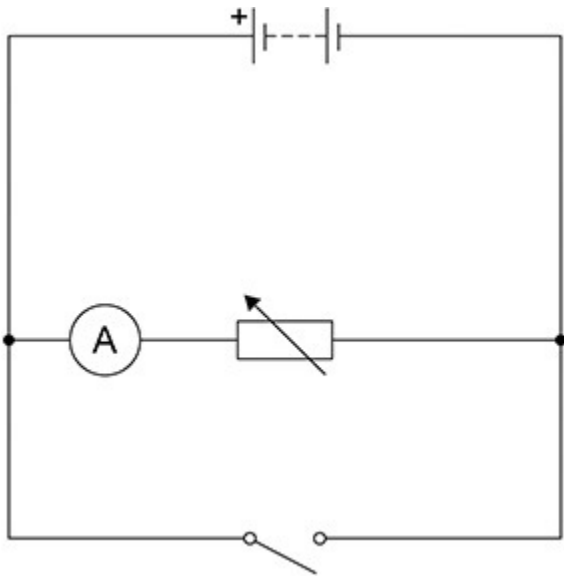

Explain how closing the switch would affect the current in the variable resistor.

(2)
(Total 8 marks)

2.

Figure 1 shows some overhead power cables in the National Grid.

Figure 1

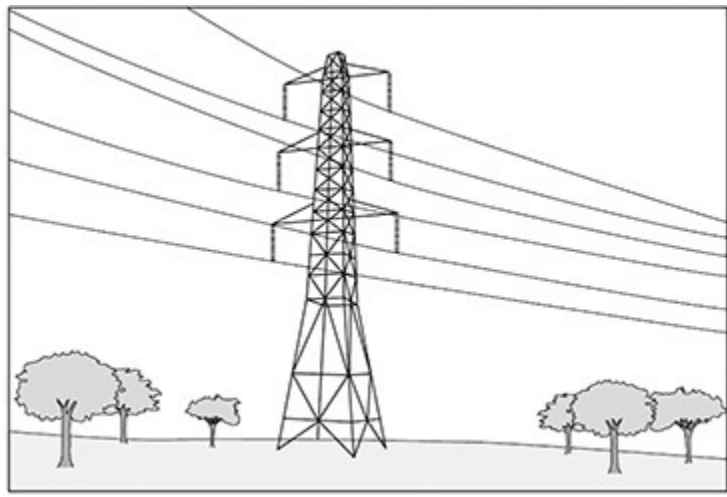

(a) Explain the advantage of transmitting electricity at a very high potential difference.

(3)

- (b) It is dangerous for a person to fly a kite near an overhead power cable.

Figure 2 shows a person flying a kite.

Figure 2



The person could receive a fatal electric shock if the kite was very close to, but not touching the power cable.

Explain why. (separate only)

(3)

A scientist investigated how the potential difference needed for air to conduct charge varies with the distance between a cable and earth.

Figure 3 shows the results.

Figure 3

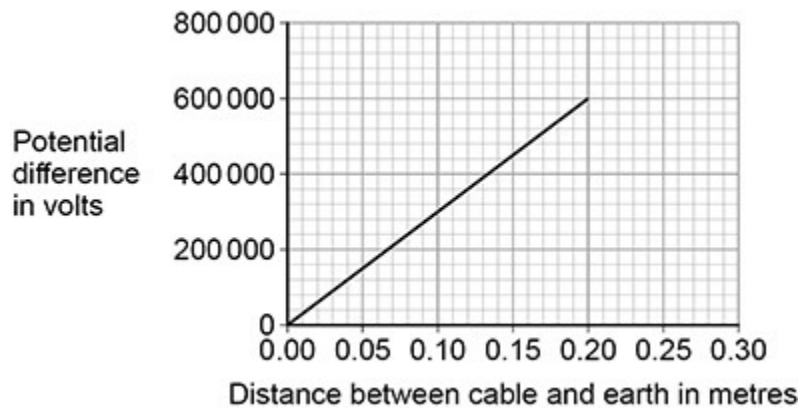

- (c) The data in **Figure 3** gives the relationship between potential difference and distance when the air is dry.

When the humidity of air increases the air becomes a better conductor of electricity.

Draw a line on **Figure 3** to show how the potential difference changes with distance if the humidity of the air increases.

(2)

(d) **Figure 4** shows a cross-section through a power cable.

Figure 4

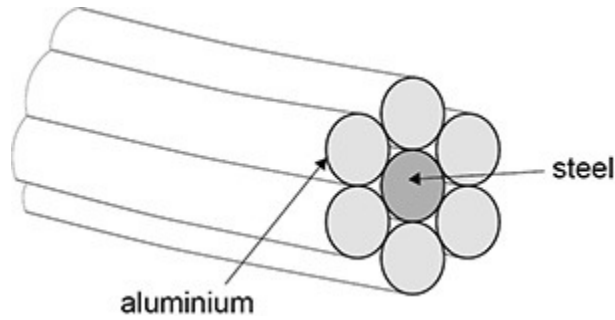

A 1 metre length of a single aluminium wire is a better conductor than a 1 metre length of the steel wire.

The individual wires behave as if they are resistors connected in parallel.

Explain why the current in the steel wire is different to the current in a single aluminium wire.

(2)
(Total 10 marks)

3. (a) Complete the sentence. Choose answers from the box.

charge	potential difference	power	temperature	time
---------------	-----------------------------	--------------	--------------------	-------------

The current through an ohmic conductor is directly proportional to the

_____ across the component, provided

that the _____ remains constant.

(2)

(b) **Figure 1** shows a current – potential difference graph for a filament lamp.

Figure 1

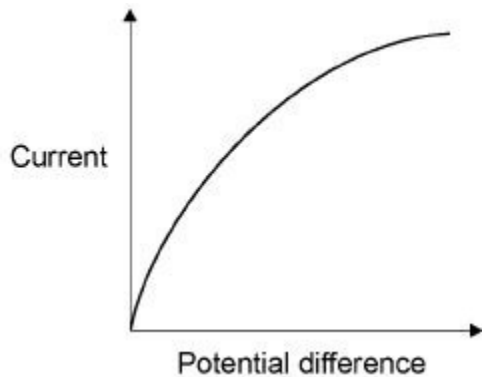

Explain how the resistance of a filament lamp changes as the potential difference across it increases.

(3)

(c) Many householders are replacing their filament lamps with LED lamps which are more energy efficient. What does more energy efficient mean?

(1)

A Light Dependent Resistor (LDR) is used to turn on an outside lamp when it gets dark.

Part of the circuit is shown in **Figure 2**.

Figure 2

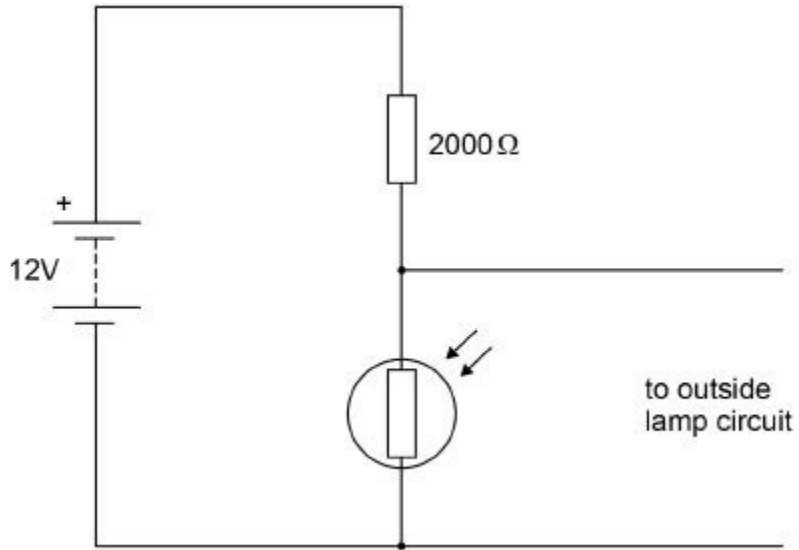

- (d) The light intensity decreases.

What happens to the potential difference across the LDR and the current in the LDR?

Potential difference _____

Current _____

(2)

- (e) What is the resistance of the LDR when the potential difference across it is 4 V?

Give a reason for your answer.

Explain your answer.

Resistance = _____ Ω

Reason _____

(2)

(f) Calculate the current through the LDR when the resistance of the LDR is 5000 Ω .

Give your answer to 2 significant figures.

Current = _____ A

(4)
(Total 14 marks)

4.

Figure 1 shows a person using an electric lawn mower.

Figure 1



(a) The lawn mower is connected to the mains electricity supply.
What is the frequency of the mains electricity supply in the UK?

Frequency = _____ Unit _____

(2)

The lawn mower has a switch on each side of the handle.

Figure 2 shows the circuit diagram for the lawn mower.

Figure 2

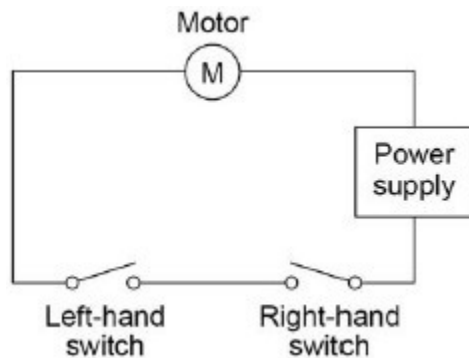

- (b) The motor in the lawn mower can only be turned on when the person using it holds the handle of the lawn mower with both hands. Explain why.

(2)

- (c) The power input to the motor is 1.8 kW

The resistance of the motor is 32 Ω

Calculate the current in the motor.

Current = _____ A

(3)

- (d) The useful power output from the motor is 1.5 kW
Calculate the time it takes for the motor to transfer 450 000 J of useful energy.

Time = _____ seconds

(3)
(Total 10 marks)

5.

The photograph below shows a coffee machine. The coffee machine uses an electric element to heat water.



- (a) The coffee machine has a metal case.
Why would it be dangerous for the live wire of the electric cable to touch the metal case?

(1)

- (b) The power output of the coffee machine is 2.53 kW.
The mains potential difference is 230 V. Calculate the current in the coffee machine.

Current = _____ A

(3)

- (c) The coffee machine heats water from 20 °C to 90 °C.
The power output of the coffee machine is 2.53 kW. The specific heat capacity of water is 4200 J/kg °C. Calculate the mass of water that the coffee machine can heat in _____ 14 _____ seconds.

Mass = _____ kg

(5)

(Total 9 marks)

6.

Figure 1 shows a student after rubbing a balloon on his hair.

The balloon and hair have become charged.

Figure 1

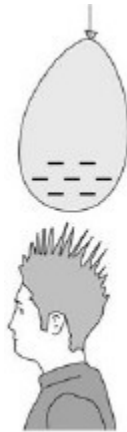

(a) Describe the force that acts on the student's hair in **Figure 1**. (separate only)

(2)

(b) An earthed conductor was brought near the charged student. A spark jumped between the conductor and the student. The potential difference

between the conductor and the student was 2.5 kV

The energy transferred by the spark was 0.0050 J

Calculate the charge transferred by the spark.

Charge = _____ C

(3)

- (c) A defibrillator can transfer a charge to regulate a person's heartbeat.

Figure 2 shows a defibrillator.

Figure 2



When the defibrillator is in use, a potential difference of 4800 V is applied across the person's chest.

A charge of 0.16 coulombs passes through the person's chest in 4.0 ms

Calculate the resistance of the person's chest.

Resistance = _____ Ω

(5)
(Total 10 marks)

7.

A student investigated how the total resistance of identical resistors connected in parallel varied with the number of resistors.

The student used an ohmmeter to measure the total resistance of the resistors.

The diagram below shows the student’s circuit with 3 resistors.

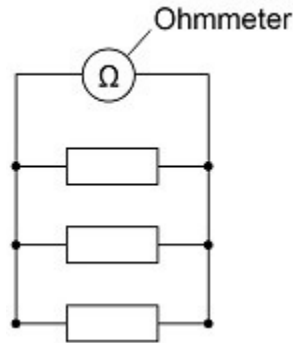

The student repeated each reading of resistance three times.

The table below shows some of the results for 3 resistors in parallel.

Number of resistors	Total resistance in ohms			
	Reading 1	Reading 2	Reading 3	Mean
3	15.8	15.3	X	15.7

(a) Calculate value **X** in the table above.

$X = \text{-----} \Omega$

(2)

(b) The student thought that taking a fourth reading would improve the precision of the results.

The fourth reading was 16.2Ω . Explain why the student was wrong.

(2)

The graph below shows the results from the investigation.

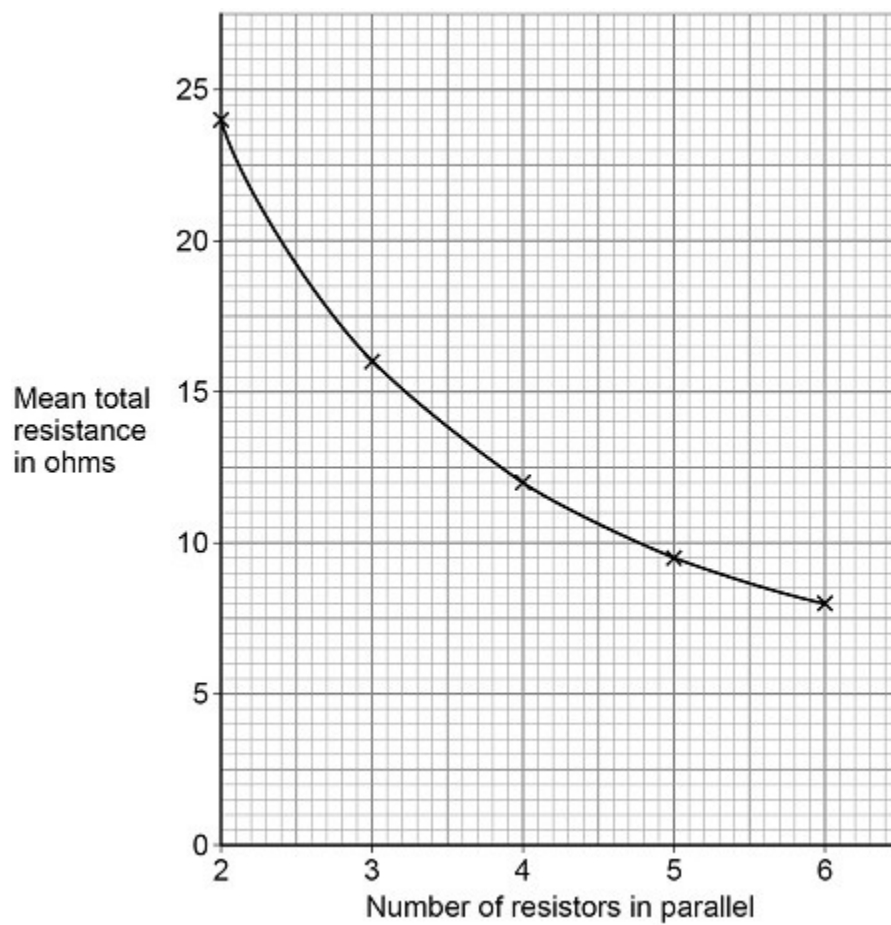

(c) The student concluded that the number of resistors in parallel was inversely proportional to the mean total resistance. Explain why the student was correct. Use data from the graph in your answer.

(3)

(d) Explain why adding resistors in parallel decreases the total resistance.

(2)

(Total 9 marks)

8.

Figure 1 shows how much electricity was generated using coal-fired and gas-fired power stations in January for 5 years in the UK.

Figure 1

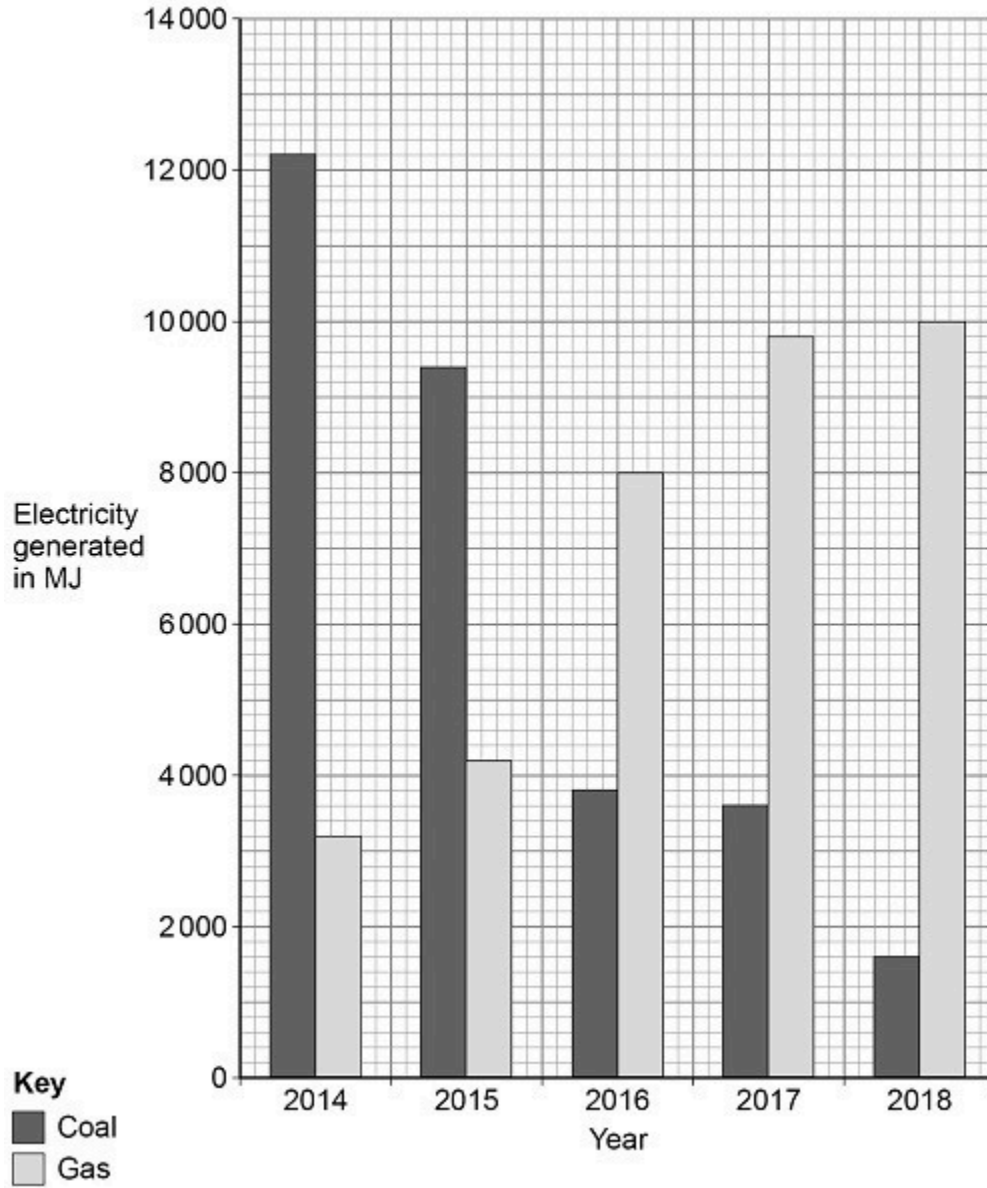

- (a) Determine the percentage increase in electricity generated using gas-fired power stations from 2014 to 2018.

Percentage increase = _____ %

(2)

- (b) Give **two** environmental advantages of using a gas-fired power station to generate electricity compared with using a coal-fired power station.

1 _____

2 _____

(2)

The mean surface temperature of the sea changes throughout the year.

A change in the mean surface temperature from year to year indicates climate change.

Figure 2 shows how the mean surface temperature changed between 1988 and 2016.

Figure 2

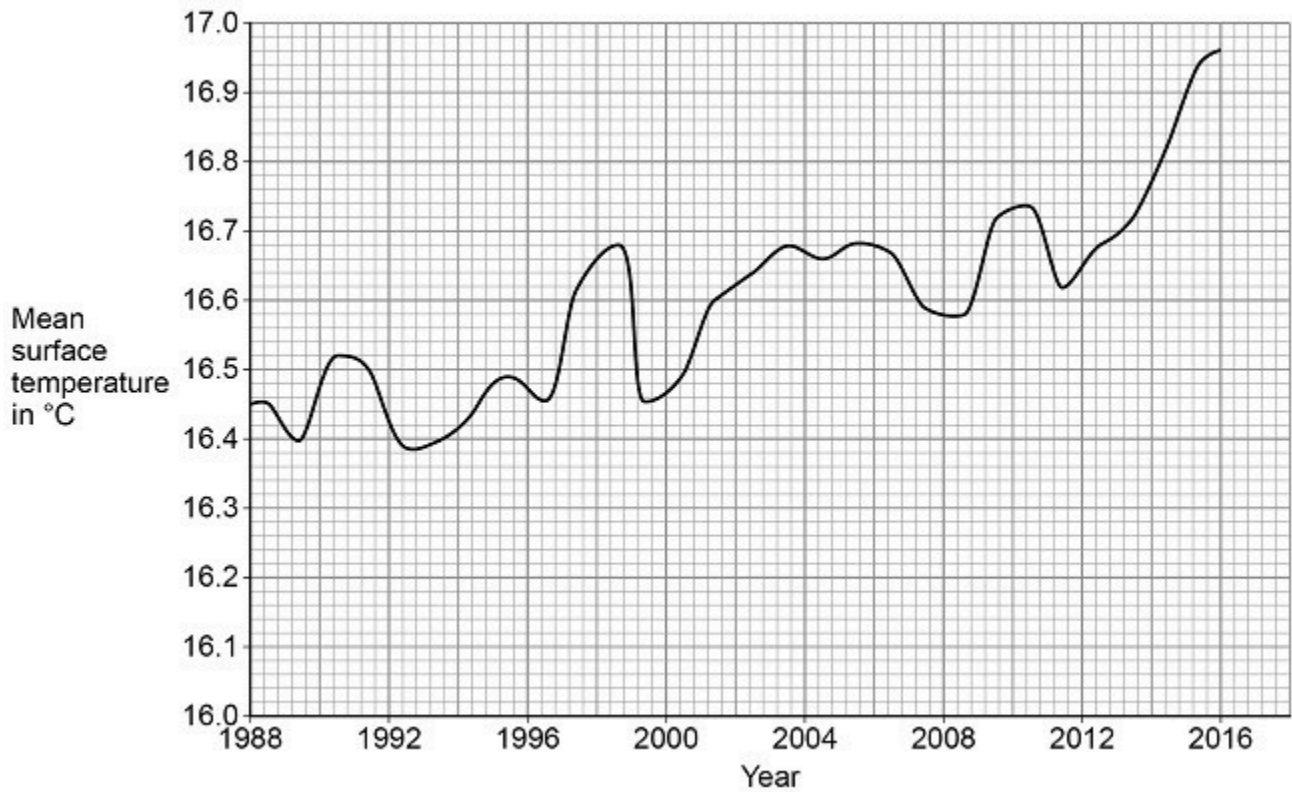

(c) A student does not believe that climate change is occurring.

Explain how the data in **Figure 2** suggests the student is wrong.

(2)

(d) A thermistor can be used to measure temperature.

Figure 3 shows how the resistance of four different thermistors A, B, C and D, varies with temperature.

Figure 3

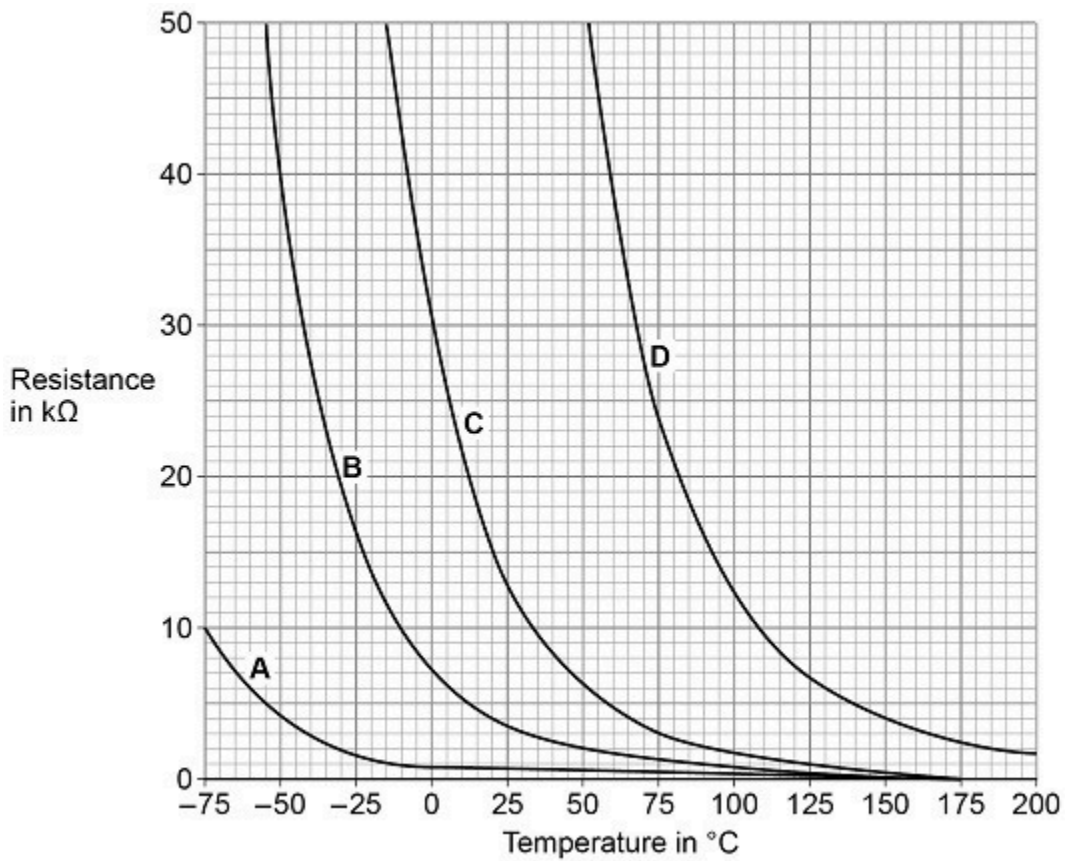

Which of the four thermistors would be the most suitable to measure the surface temperature of the sea?

Tick (✓) **one** box.

Explain your answer.

A	B	C	D
<input type="checkbox"/>	<input type="checkbox"/>	<input type="checkbox"/>	<input type="checkbox"/>

(3)
(Total 9 marks)

9.

The diagram below shows part of a mains electricity lighting circuit in a house.

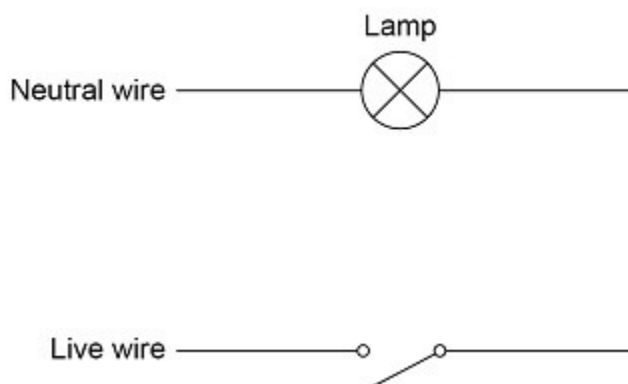

- (a) A fault in the switch caused a householder to receive a mild electric shock before a safety device switched the circuit off. The mean power transfer to the person was 5.75 W.

The potential difference across the person was 230 V. Calculate the resistance of the person.

Resistance = _____ Ω

(5)

- (b) An electrician replaced the switch.
The electrician would have received an electric shock unless the circuit was disconnected from the mains supply.

Explain why.

(3)

- (c) The current from an electric shock causes a person's muscles to contract. The person cannot let go of the electrical circuit if the current is too high.

The graph below shows how the maximum current at which a person can let go depends on the frequency of the electricity supply.

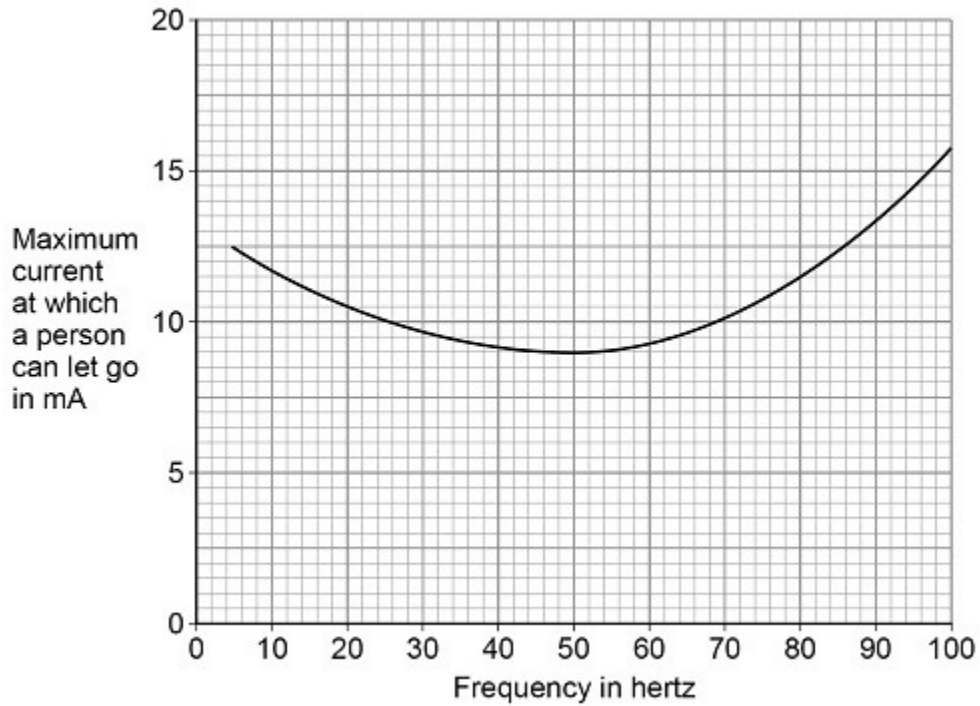

The UK mains frequency is 50 Hz. Explain why it would be safer if the UK mains frequency was **not** 50 Hz.

(2)
(Total 10 marks)