

## Power

### Questions

Q1.

A cyclist is riding a bicycle at a steady velocity of 12 m/s.

The cyclist and bicycle have a total mass of 68 kg.

\* A class of students investigate the power output of each student in the class.

The class must decide whether they use a method using steps or a method using weights.

The whole class must use the same method.

Plan what measurements the students should take and how these can be used to calculate and compare the power output of each student.

You may draw a diagram to help with your plan.

(6)

.....

.....

.....

.....

.....

.....

.....

.....

.....

.....

.....

.....

.....

.....

.....

(Total for question = 6 marks)

Q2.

An athlete uses a training machine in a gym.

The display on the machine shows the time spent on the machine and the amount of energy transferred during a training session.

Figure 5 shows the displays for two different sessions by the same athlete.

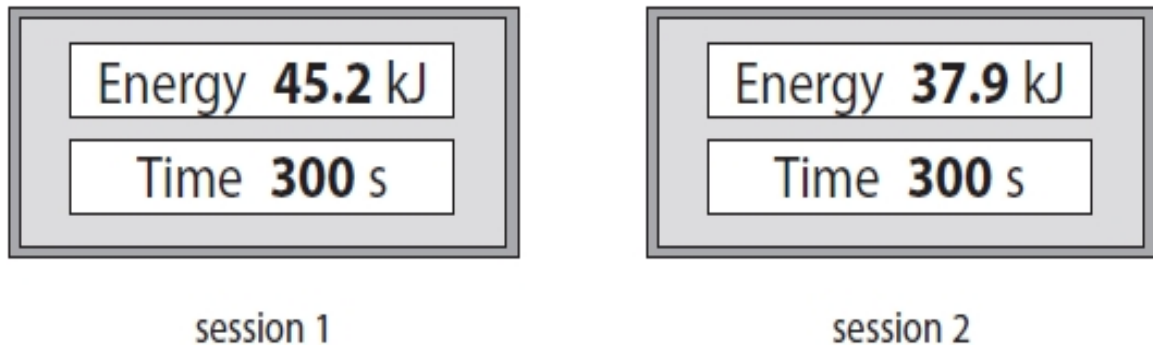

Figure 5

Explain what the displays show about the average power of the athlete in each of these two sessions.

(2)

.....

.....

.....

.....

.....

(Total for question = 2 marks)

Q3.

This question is about using the mains electricity supply.

(i) An electric kettle is used to boil some water.

The mains supply voltage is 230 V.

The power supplied to the kettle is 1.9 kW.

Calculate the current in the kettle.

Use the equation

$$I = \frac{P}{V}$$

(2)

current supplied to the kettle = ..... A

(ii) A coffee machine takes 120 s to heat some water.

Mains supply voltage = 230 V

Current in this coffee machine = 7.4 A

Calculate the energy transferred to the coffee machine in 120 s.

Use an equation selected from the list of equations at the end of the paper.

(2)

energy transferred to coffee machine = ..... J

(Total for question = 4 marks)

Q4.

Figure 14 shows an athlete using a fitness device.

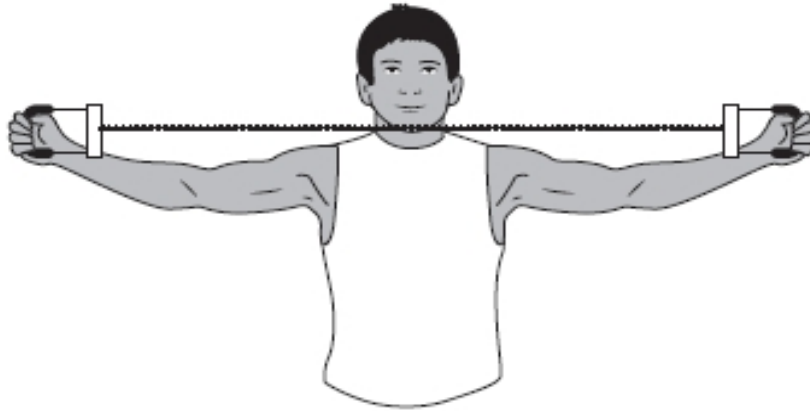

**Figure 14**

The athlete stretches the spring in the device by pulling the handles apart.

The spring constant of the spring is 140 N/m.

The athlete does 45 J of work to extend the spring.

The athlete takes 0.6 s to expand the spring.

(i) Calculate the useful power output of the athlete when stretching the spring.

(2)

useful power output of the athlete = ..... W

(ii) Calculate the extension of the spring.

Use an equation selected from the list of equations at the end of this paper.

(3)

extension of the spring = ..... m

(Total for question = 5 marks)

Q5.

(i) Complete the equation that relates efficiency, useful energy transferred by a device and total energy supplied to the device.

(1)

efficiency .....

(ii) In one second an engine has a total energy input of 7500 J.

In one second 3200 J is transferred to the surroundings as wasted energy.  
Calculate the useful energy transferred by the engine.

(1)

useful energy transferred = .....

(iii) Calculate the efficiency of this engine.

(2)

efficiency of the engine = .....

(Total for question = 4 marks)

Q6.

Figure 14 shows the vertical forces on an aeroplane.

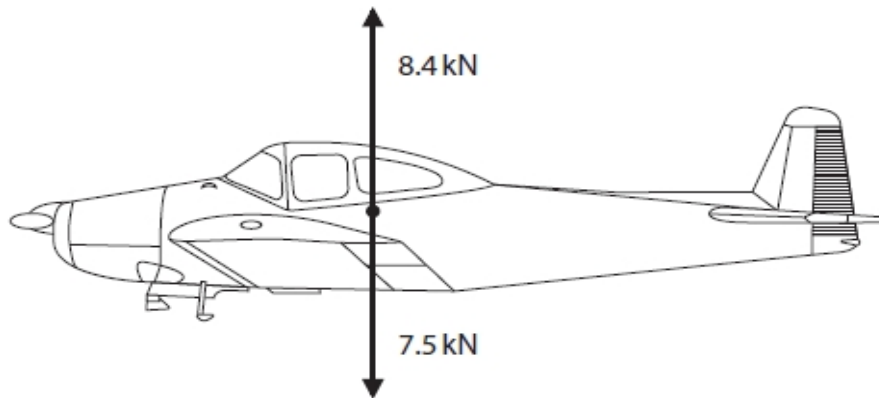

Figure 14

The aeroplane is powered by an engine that burns fuel.

The fuel supplies a total of 6500 kJ of energy every minute.

The efficiency of the engine is 0.70 (70%).

(i) Calculate the power output of the engine.

Give your answer in kW.

(4)

power = ..... kW

(ii) Explain why the efficiency of the engine is less than 1 (100%).

(2)

.....  
.....  
.....  
.....

(Total for question = 6 marks)

**Mark Scheme - Power**

Q1.

Question Number:	Answer	Mark
	<p>Answers will be credited according to candidate's deployment of knowledge and understanding of the material in relation to the qualities and skills outlined in the generic mark scheme.</p> <p>The indicative (example) content below is not prescriptive and candidates are not required to include all the material which is indicated as relevant. Additional content included in the response must be scientific and relevant.</p> <p>Indicative content</p> <ul style="list-style-type: none"> <li>• Description of an experiment which will allow work done over a given time to be measured.</li> <li>• E.g. running upstairs, step-ups, lifting weights</li> <li>• Apparatus to be used, weighing scales, known weights ruler, stop clock</li> <li>• Measurements to be made</li> <li>• E.g. weight of person/weights lifted, vertical distance moved, time taken.</li> <li>• Calculation of work done for each student using <math>\text{work done} = \text{force} \times \text{distance moved in direction of force}</math></li> <li>• Calculation of power for each student using <math>\text{power} = \text{work done} / \text{time taken}</math></li> </ul> <p>Comparison of powers by lifting same weights, in a constant time and comparing the distance moved</p>	<p><b>(6)</b> AO 2 2</p>

Level	Mark	Descriptor
	0	<ul style="list-style-type: none"> <li>No awardable content</li> </ul>
Level 1	1–2	<ul style="list-style-type: none"> <li>The plan attempts to link and apply knowledge and understanding of scientific enquiry, techniques and procedures, flawed or simplistic connections made between elements in the context of the question. (AO2)</li> <li>Analyses the scientific information but understanding and connections are flawed. An incomplete plan that provides limited synthesis of understanding. (AO3)</li> </ul>
Level 2	3–4	<ul style="list-style-type: none"> <li>The plan is mostly supported through linkage and application of knowledge and understanding of scientific enquiry, techniques and procedures, some logical connections made between elements in the context of the question. (AO2)</li> <li>Analyses the scientific information and provides some logical connections between scientific enquiry, techniques and procedures. A partially completed plan that synthesises mostly relevant understanding, but not entirely coherently. (AO3)</li> </ul>
Level 3	5–6	<ul style="list-style-type: none"> <li>The plan is supported throughout by linkage and application of knowledge and understanding of scientific enquiry, techniques and procedures, logical connections made between elements in the context of the question. (AO2)</li> <li>Analyses the scientific information and provide logical connections between scientific concepts throughout. A well-developed plan that synthesises relevant understanding coherently. (AO3)</li> </ul>



Q2.

Question Number:	Answer	Additional Guidance	Mark
	<p>an explanation linking:</p> <p>over the <b>same time / in 300s</b>, more work done / energy transferred in session 1 than in session 2 (1)</p> <p>(therefore) more power (developed) in session 1 (1)</p>	<p>allow reverse argument</p> <p>power in session 1 = <math>\frac{45.2}{300} = 0.15</math> (kW) or 150(W)</p> <p>allow statement that power = <math>\frac{\text{work}}{\text{time}}</math> or power = <math>\frac{\text{energy}(\text{transferred})}{\text{time}}</math></p> <p>for MP1</p> <p>power in session 2 = <math>\frac{37.9}{300} = 0.13</math> (kW) or 126(W)</p>	<p><b>(2)</b> AO 3 2a AO 3 2b</p>

Q3.

Question number	Answer	Additional guidance	Mark
i	<p>substitution (1)</p> $(I = \frac{P}{V}) = \frac{1.9 \text{ (x } 10^3)}{230} \text{ (1)}$ <p>evaluation (1)</p> <p>8.3 (A)</p>	<p>8.3 / 8.26 (A)</p> <p>award full marks for correct answer without working</p> <p>award one mark for <math>8.26 \times 10^{-3} / 0.0083</math></p>	<p><b>(2)</b> AO2</p>

## 8.2 Power

Question number	Answer	Additional guidance	Mark
ii	choice and substitution (1) $E = I \times V \times t$ $= 7.4 \times 230 \times 120$  evaluation (1)  200000 (J)	accept 204000 / 204240  award full marks for correct answer without working  award 1 mark for 3400 / 3404 (J) (using 2 minutes as time)	(2) AO2

Q4.

Question Number	Answer	Additional guidance	Mark
(i)	recall (1) $(P =) \frac{E}{t}$  substitution and evaluation (1) $(P =) 75 \text{ (W)}$	$P = \text{work done} \div \text{time}$ $P = \frac{45}{0.6}$  award full marks for the correct answer without working	(2)

Question Number	Answer	Additional guidance	Mark
(ii)	substitution into $E = \frac{1}{2} \times k \times x^2$ (1)  $45 = \frac{1}{2} \times 140 \times x^2$  rearrangement (1)  $(x =) \sqrt{\frac{2 \times 45}{140}}$  evaluation (1) 0.8(0) (m)	allow substitution and rearrangement in either order   $x^2 = \left(\frac{E}{0.5k}\right) = \frac{2 \times 45}{140}$  $x^2 = 0.64(28571)$  accept values that round to 0.80 e.g. 0.80178  award full marks for the correct answer without working	(3)

Q5.

Question Number:	Answer	Mark
(i)	efficiency = $\frac{\text{useful (energy transferred by the device)} (x100)}{\text{total (energy supplied to the device)}}$	(1) AO 1 1

Question Number:	Answer	Additional guidance	Mark
(ii)	determine useful energy (1) $7500 - 3200 = 4300$		(1) AO 2 1

Question Number:	Answer	Additional guidance	Mark
(iii)	substitution (1)  efficiency = $\frac{4300}{7500}$  evaluation (1) 0.57	allow ECF from (i) and/ or (ii) for 1 mark maximum   accept 57(.33)(%), 0.6, 60(%)  award full marks for the correct answer without working	(2) AO 2 1

Q6.

Question Number:	Answer	Additional Guidance	Mark
(i)	<p>recall efficiency equation (1)</p> $\text{efficiency} = \frac{\text{useful output}}{\text{input}}$ <p>rearrangement (1)</p> <p>output energy = 0.70 x 6500</p> <p>recall power equation (1)</p> $\text{power} = \frac{\text{energy}}{\text{time}}$ <p>evaluation (1)</p> <p>(power =) 76 (kW)</p>	<p>efficiency = <math>\frac{\text{power output}}{\text{power input}}</math></p> <p>4550 (kJ) seen scores 2 marks (from 0.7 x 6500 (kJ))</p> $\frac{4550}{60}$ <p>accept ecf from output energy</p> <p>accept values that round up to 76 (kW) e.g. 75.8</p> <p>award full marks for correct answer without working</p>	<p><b>(4)</b> AO 1 1 AO 2 1</p>

Question Number:	Answer	Additional Guidance	Mark
(ii)	<p>an explanation linking:</p> <p>(useful) output energy is less than input energy (1)</p> <p>some energy is transferred to less useful forms (1)</p>	<p>input energy is greater than output energy</p> <p>(only) 70% of the input energy is useful</p> <p>energy is dissipated / wasted / lost (to surroundings)</p> <p>energy is lost / transferred as thermal / heat</p> <p>30% is lost /dissipated / wasted / lost for 2 marks</p>	<p><b>(2)</b> AO 1 1</p>