

Energy Changes

Questions

Q1.

A ball has a mass of 0.046 kg.

(i) Calculate the change in gravitational potential energy when the ball is lifted through a vertical height of 2.05 m.

Use the equation

$$\Delta GPE = m \times g \times \Delta h \tag{2}$$

change in gravitational potential energy = J

(ii) The ball is released.

Calculate the kinetic energy of the ball when the speed of the ball is 3.5 m/s. (3)

kinetic energy of the ball = J

(iii) The ball bounces several times.

Figure 15 shows how the height of the ball above the floor changes with time.

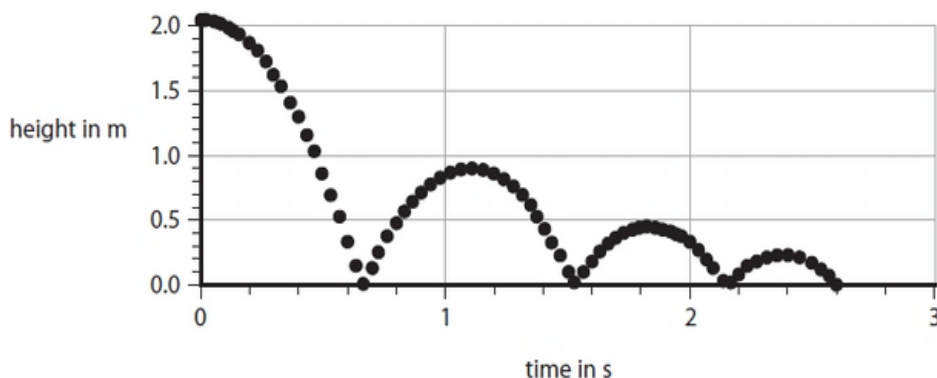

Figure 15

Use Figure 15 to estimate the maximum height that the ball reaches after the first bounce.

(1)

height after first bounce = m

8.1 Energy Changes

(iv) Explain why the ball does not bounce back to its starting height of 2.05 m.

(2)

.....

.....

.....

(Total for question = 8 marks)

Q2.

This question is about energy changes.

Figure 11 shows a water slide.

A person travels from the top to the bottom of the water slide.

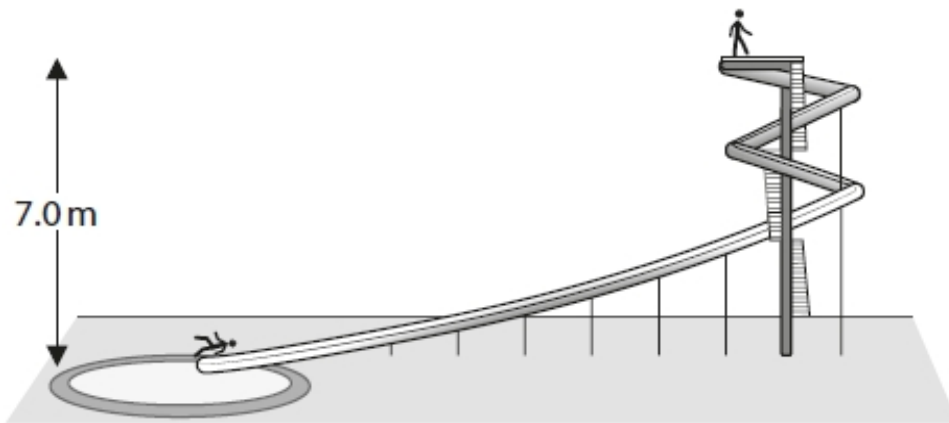

Figure 11

- (i) The mass of the person, $m = 72 \text{ kg}$.
The change in vertical height, $h = 7.0 \text{ m}$
Gravitational field strength, $g = 10 \text{ N / kg}$

Calculate the change in gravitational potential energy for the person.
Use the equation

$$\text{change in gravitational potential energy} = m \times g \times h$$

(2)

change in gravitational potential energy = J

8.1 Energy Changes

(ii) The person comes to rest after the end of the water slide.

Explain what happens to the energy as the person comes to rest after the end of the water slide.

(2)

.....
.....

(Total for question = 4 marks)

Q3.

A drone has a mass of 4.5 kg.

This drone rises from the ground to a height of 20 m.

(i) Calculate the change in gravitational potential energy when the drone rises through a height of 20 m.

The gravitational field strength $g = 10 \text{ N/kg}$.

(2)

change in gravitational potential energy = J

(ii) State the amount of useful work done by the blades as the drone rises through 20 m.

(1)

useful work done = J

(iii) It takes 4s for the drone to rise through 20m.

Calculate the useful power developed by the blades in this time of 4 s.

(2)

useful power developed = W

(Total for question = 5 marks)

8.1 Energy Changes

Q4.

This question is about energy changes.

Calculate the kinetic energy of a tennis ball travelling at 28 m/s.
The mass of the tennis ball = 58 g.

Use the equation

$$KE = \frac{1}{2} \times m \times v^2$$

(3)

kinetic energy = J

(Total for question = 3 marks)

Q5.

Figure 21 shows a bicycle.



Figure 21

(i) The rider uses the pedals to make the large gear wheel turn.

The large gear wheel moves the chain.
The chain turns the small gear wheel.

The large gear wheel has 48 teeth.
The small gear wheel has 12 teeth.

The large gear wheel turns 2 times each second.

Calculate the number of times that the small gear wheel turns each second.

(2)

..... turns each second

(ii) Oil is applied to the wheel of a bicycle at the point shown in Figure 22.

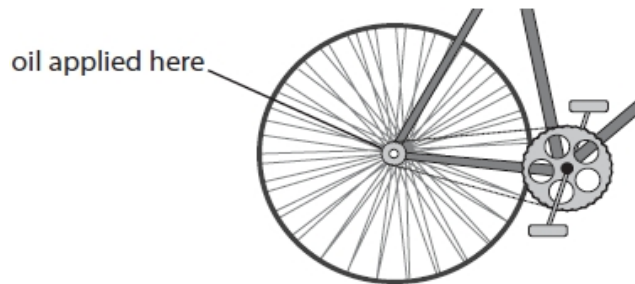

Figure 22

Explain how the oil improves the efficiency of the bicycle.

(3)

.....

.....

.....

.....

.....

(Total for question = 5 marks)

8.1 Energy Changes

Q6.

The kinetic energy of another cyclist is 2800 J.

The mass of the cyclist is 85 kg.

Calculate the velocity of this cyclist.

Use the equation

$$KE = \frac{1}{2} \times m \times v^2$$

(3)

velocity = m / s

(Total for question = 3 marks)

Q7.

Figure 10 shows a toy used to launch a ball.

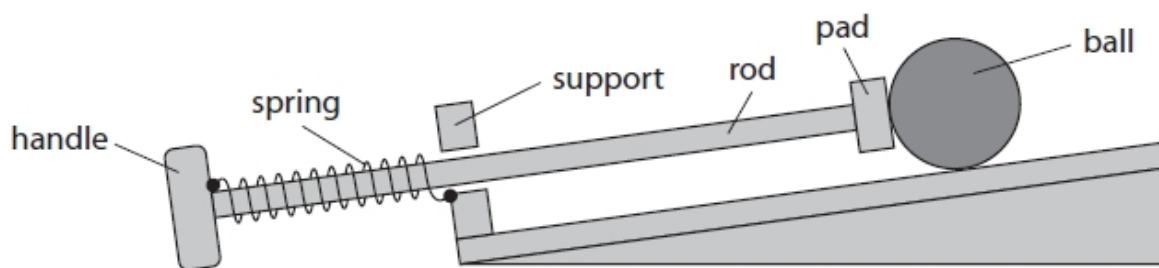

Figure 10

One end of the spring is fixed to the handle.

The other end of the spring is fixed to the support.

The child pulls the handle until the pad is against the support as shown in Figure 12.

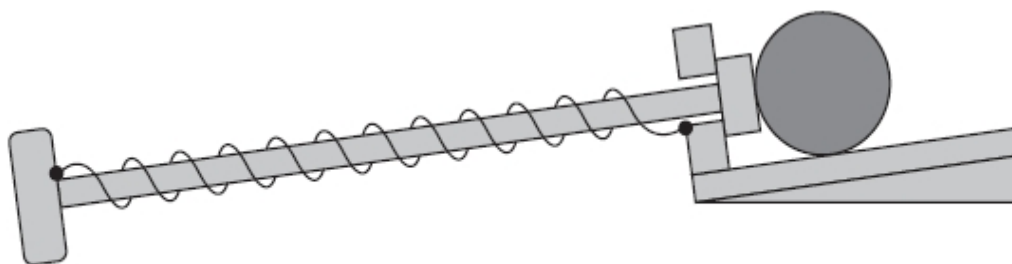

Figure 12

(i) The extension of the spring is 0.09 m.

The spring constant (k) is 20 N/m.

Calculate the work done in extending the spring by 0.09 m.

Use the equation

$$\text{work done} = \frac{1}{2} \times k \times (\text{extension})^2$$

(2)

work done = J

8.1 Energy Changes

(ii) The child lets go of the handle.

The ball starts to move.

The spring returns to its original length.

Describe the energy transfer that takes place when the ball starts to move.

(2)

.....

.....

.....

.....

(iii) The child can only stretch the spring until the pad is pressing against the support.

Explain how the design of the toy prevents the spring from becoming damaged.

(2)

.....

.....

.....

(Total for question = 6 marks)

Q8.

A cyclist is riding a bicycle at a steady velocity of 12 m/s.

The cyclist and bicycle have a total mass of 68 kg.

Calculate the kinetic energy of the cyclist and bicycle.

Use the equation

$$KE = \frac{1}{2} \times m \times v^2$$

(2)

kinetic energy = J

(Total for question = 2 marks)

Q9.

A student plots a graph showing the height at the start and the maximum height reached after each bounce.

Figure 16 shows the student's graph.

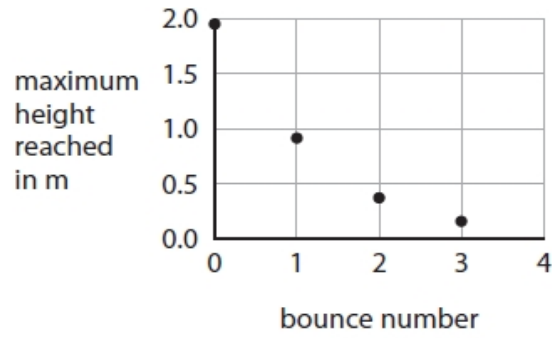

Figure 16

Describe how the maximum height reached changes with the bounce number in Figure 16.

(2)

.....

.....

.....

.....

(Total for question = 2 marks)

8.1 Energy Changes

Q10.

*Figure 23 shows a drone.



© Liubov Kotliar/123RF

Figure 23

The blades on the drone are turned by electric motors.

The electric motors are powered by a battery.

Figure 25 represents the energy transfers involved when the drone rises from the ground.

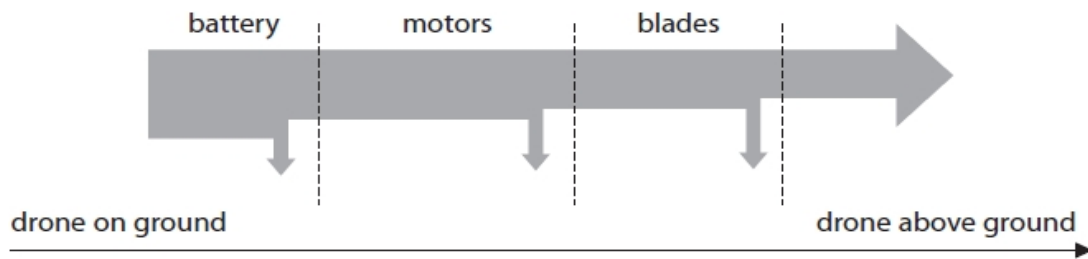

Figure 25

Describe the changes in the way energy is stored when the drone rises from the ground.

Your answer should refer to energy transfers.

(6)

.....

.....

.....

.....

.....

.....

.....

.....

.....

.....

(Total for question = 6 marks)

8.1 Energy Changes

Q11.

A cyclist is riding a bicycle at a steady velocity of 12 m/s.

The cyclist and bicycle have a total mass of 68 kg.

Describe the energy transfers that happen when the cyclist uses the brakes to stop.

(2)

.....

.....

.....

.....

(Total for question = 2 marks)

Q12.

This question is about energy changes.

Figure 12 shows a person pushing a box from the bottom of a slope to the top of the slope.

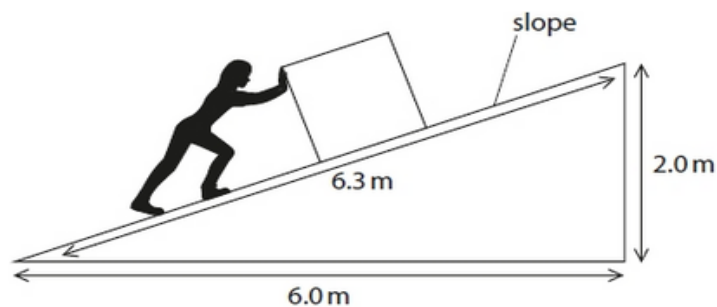

Figure 12

Explain which one of the three distances shown in Figure 12 should be used to calculate the work done against the force of friction between the box and the slope.

(2)

.....

.....

.....

.....

(Total for question = 2 marks)

Q13.

8.1 Energy Changes

(i) Figure 14 shows the vertical forces on an aeroplane.

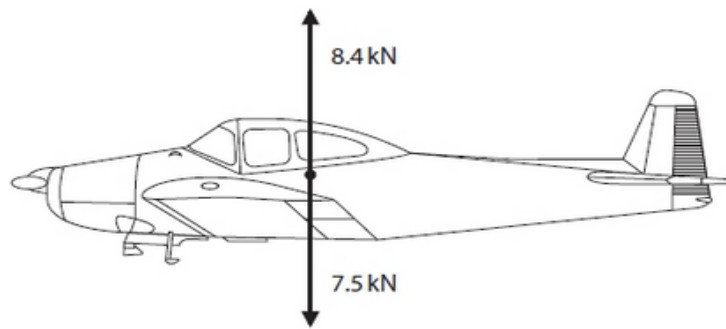

Figure 14

Use information from the diagram to determine the size and direction of the resultant vertical force on the aeroplane.

(2)

size = kN, direction is

(ii) The aeroplane is descending.

Figure 15 shows a diagram of the resultant vertical and horizontal forces on the aeroplane as it is descending.

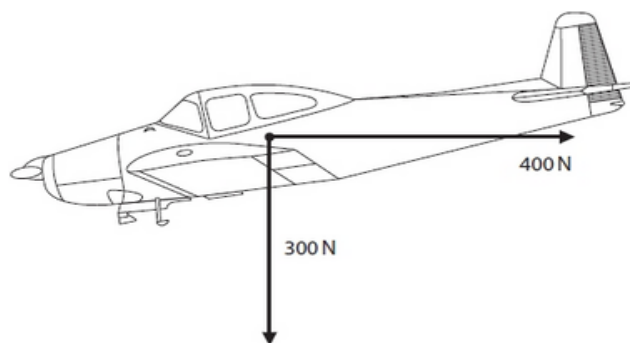

Figure 15

Complete the diagram to show the resultant of these two forces.

(1)

(iii) The mass of the aeroplane is 750 kg.

Calculate the change in gravitational potential energy of the aeroplane as it descends from 1300 m to the ground.

Gravitational field strength (g) = 10 N/kg

(2)

energy = J

(Total for question = 5 marks)

Q14.

Two cyclists ride on a hilly road and go through points P, Q, R and S.

The diagram in Figure 16 shows how the vertical height of the road changes during the journey from P to S.

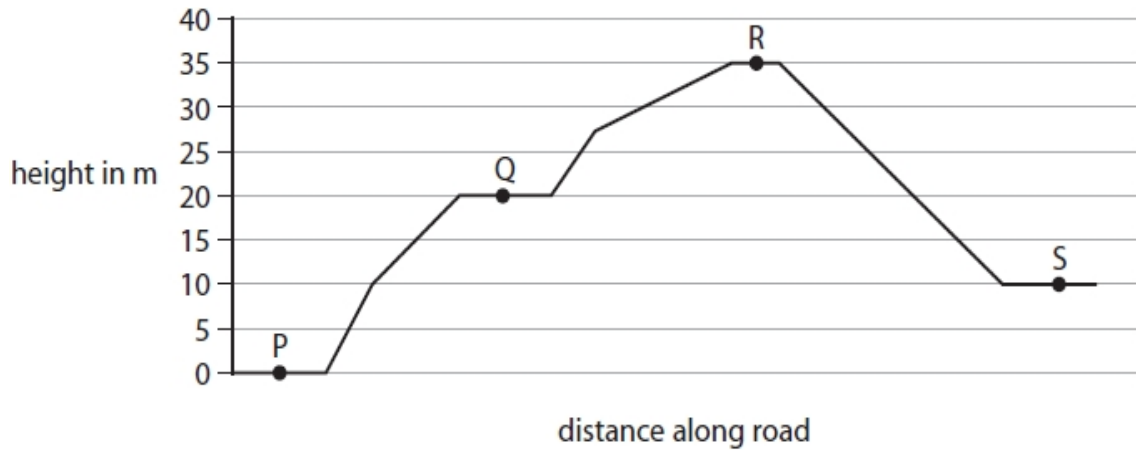

Figure 16

(i) The greatest overall change in gravitational potential energy for each cyclist is between which two points on the journey?

(1)

- A P and Q
- B Q and R
- C P and S
- D R and S

(ii) The total weight of one cyclist and bicycle is 700 N.

Calculate the total amount of work done against gravity when the cyclist travels from point P to point Q in the journey.

(2)

work done = J

8.1 Energy Changes

(iii) The gravitational potential energy of the other cyclist changes by 11 250 J when travelling from point Q to point R.

Calculate the mass of this cyclist.

Gravitational field strength = 10 N / kg

Use the equation

$$\Delta GPE = m \times g \times \Delta h$$

(2)

mass = kg

(iv) Explain why the total amount of work done by a cyclist between points Q and R is different from the change in gravitational potential energy of the cyclist between points Q and R.

(2)

.....

.....

.....

.....

(v) The cyclists lubricated the chains and the wheel bearings of their bicycles before setting off.

Lubricating the chains and wheel bearings helps to

(1)

- A decrease the amount of work done against gravity
- B decrease the efficiency of the cyclist and bicycle
- C increase the efficiency of the cyclist and bicycle
- D increase the overall amount of energy transferred by the cyclist

(Total for question = 8 marks)

Q15.

Which of these is the equation for work done?

(1)

- A work done = force \div distance moved in direction of force
- B work done = force \times distance moved in direction of force
- C work done = force \div distance moved at right angles to direction of force
- D work done = force \times distance moved at right angles to direction of force

(Total for question = 1 mark)

Q16.

Figure 8 shows part of a cart.

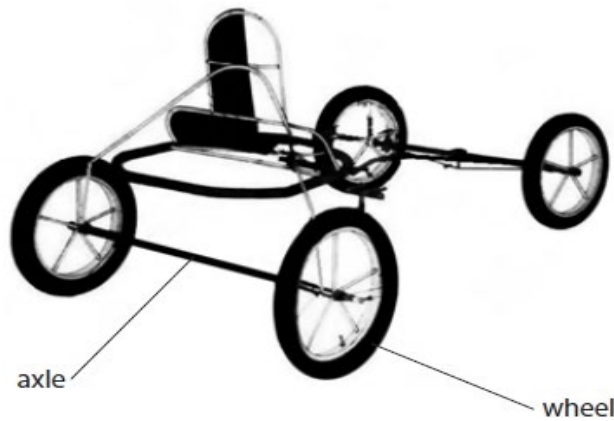

Figure 8

When the wheels turn the axles become warm.

(i) Explain why the axles become warm when the wheels turn.

(2)

.....

.....

.....

.....

(ii) Give one way of reducing the heating of the axles when the wheels turn.

(1)

.....

.....

(Total for question = 3 marks)

Mark Scheme – Energy Changes

Q1.

Question Number	Answer	Additional guidance	Mark
(i)	substitution (1) ($\Delta GPE =$) $(0.0)46 \times 10 \times 2.05$ evaluation (1) 0.94(3) (J)	allow $g=9.8(1) \text{ m/s}^2$ 0.9 (J) values that round to 0.92 or 0.93 (from using $g = 9.8$ or 9.81) do not award for 1(J) no POT error in evaluation award full marks for the correct answer without working.	(2)
Question Number	Answer	Additional guidance	Mark
(ii)	recall (1) ($KE =$) $\frac{1}{2} \times m \times v^2$ substitution (1) ($KE =$) $\frac{1}{2} \times (0.0)46 \times 3.5^2$ evaluation (1) 0.28 (J)	allow answers that round to 0.28 e.g. 0.28175 (J) allow max 2 marks for POT error e.g. 0.00028 award full marks for the correct answer without working	(3)
Question Number	Answer	Additional guidance	Mark
(iii)	Any value between 0.8 (m) and 0.95 (m) inclusive		(1)

8.1 Energy Changes

Question Number	Answer	Additional guidance	Mark
(iv)	An explanation linking (the ball) has lost energy (1) identification of what has happened to that energy (1)	accept (energy) dissipated or (transferred to) surroundings / ground or thermal energy or heat / sound or system is not 100% efficient or bounce is not (100%) elastic or squashing (the ball or the ground)	(2)

Q2.

Question number	Answer	Additional guidance	Mark
i	substitution (1) $(\Delta GPE) = 72 \times 10 \times 7.0$ evaluation (1) 5040 (J)	do not penalise any power of ten error (p.o.t.e.) at this stage do not accept an answer without value for g (10 being used) award full marks for correct answer without working	(2) AO2

8.1 Energy Changes

Question number	Answer	Additional guidance	Mark
ii	<p>an explanation to include</p> <p>(potential / kinetic) energy is transferred / dissipated (1)</p> <p>to surroundings / water / air / slide (1)</p>	<p>accept lost / decreases</p> <p>accept friction / air resistance acts</p> <p>accept to thermal (store)</p>	(2) AO3

Q3.

Question number	Answer	Additional guidance	Mark
(i)	<p>recall and substitution into (1)</p> $gpe = m \times g \times h$ $(gpe) = 4.5 \times 10 \times 20$ <p>evaluation (1)</p> <p>900(J)</p>	<p>allow 90(J) for 1 mark</p> <p>award full marks for the correct answer without working</p>	(2)

Question number	Answer	Additional guidance	Mark
ii	900(J)	allow ecf from bi	(1)

Question number	Answer	Additional guidance	Mark
iii	<p>recall and substitution (1)</p> <p>power = work done / time taken</p> $(power =) 900 / 4$ <p>evaluation (1)</p> <p>200 (W)</p>	<p>allow ecf from bi or bii</p> <p>230(W)</p> <p>225(W)</p> <p>award full marks for the correct answer without working</p>	(2)

8.1 Energy Changes

Q4.

Question number	Answer	Additional guidance	Mark
	substitution (1) $KE = \frac{1}{2} \times 58 (\times 10^{-3}) \times 28^2$ conversion (1) uses 58×10^{-3} or 0.058 evaluation (1) 23 (J)	do not penalise p.o.t.e. at this stage award full marks for any answer that rounds to 23 (e.g. 22.736) (J) award max two marks for any answer that rounds to 2.3 to any other power of 10 consolation mark for not squaring 28 (8.1(2) to any p.o.t.) (maximum 1 mark)	(3) AO2

8.1 Energy Changes

Q5.

Question Number	Answer	Additional guidance	Mark
(i)	<p>(In every second), distance moved by chain around large gear = distance moved by chain around small gear (1)</p> <p>$2 \times 48 = \text{turns} \times 12$</p> <p>rearrangement and evaluation (1)</p> <p>8 (turns each second)</p>	<p>accept use of gear ratio seen or implied e.g. 4:1 or 4/1 or 48:12 or 48/12 or converse e.g. 1:4</p> <p>award full marks for the correct answer without working</p>	(2)

Question Number	Answer	Additional guidance	Mark
(ii)	<p>An explanation linking</p> <p>reduces friction/amount of thermal energy transferred (1)</p> <p>extra useful energy is available/less input energy is required (1)</p> <p>efficiency = useful energy transferred (by the bicycle) ÷ total energy supplied (to the bicycle) (1)</p>	<p>(oil provides) lubrication</p> <p>less energy wasted</p> <p>allow for the last two mark points; either less input energy is required to produce the same output for 2 marks or more output energy is available for the same input energy for 2 marks</p>	(3)

8.1 Energy Changes

Q6.

Question number	Answer	Additional guidance	Mark
	substitution (1) $2,800 = \frac{1}{2} \times 85 \times v^2$ rearrangement (1) $(v^2 =) \frac{2800 \times 2}{85}$ evaluation (1) $v = 8.1 \text{ (m/s)}$	allow substitution and rearrangement in either order 66 or 65.88 seen allow values that round to 8.1 e.g 8.1168 award full marks for the correct answer without working	(3) AO2

Q7.

Question number	Answer	Additional guidance	Mark
i	substitution (1) $(E =) \frac{1}{2} \times 20 \times 0.09^{(2)}$ evaluation (1) $0.08(1) \text{ (J)}$	allow 1 mark for $\frac{1}{2} \times 20 \times 9^2$ or answer of 810 (J) or answer of 90 (J) award full marks for the correct answer without working	(2)

8.1 Energy Changes

Question number	Answer	Additional guidance	Mark
ii	<p>a description including</p> <p>mention of one relevant energy store (1)</p> <p>correct transfer in context (1)</p>	<p>potential/ PE/ kinetic/ KE/ thermal/ heat/ elastic</p> <p>potential energy stored in the spring transferred to kinetic energy of the ball/rod scores 2 marks</p> <p>kinetic energy of rod is transferred to kinetic energy of ball scores 2 marks</p> <p>idea of energy transferred to the surroundings/ thermal scores 2 marks</p>	(2)

Question number	Answer	Additional guidance	Mark
iii	<p>an explanation linking two from</p> <p>(controls the maximum) extension (1)</p> <p>idea of keeping below the elastic limit (1)</p> <p>(which would result in) spring being permanently stretched (1)</p>	<p>ignore <u>damaging the</u> spring (given in stem)</p> <p>stretch</p> <p>prevents spring being over-stretched / extended too far scores 2 marks</p> <p>allow distorted/ break</p>	(2)

Q8.

Question Number:	Answer	Additional guidance	Mark
	substitution (1) $(KE =) \frac{1}{2} \times 68 \times 12^2$ evaluation (1) 4900 (J)	$\frac{1}{2} \times 68000 \times 12^2$ scores 1 mark accept values that round to 4900(J) e.g. 4896(J) award full marks for correct answer without working	(2) AO 2 1

Q9.

Question Number	Answer	Additional guidance	Mark
	A description to include: as the bounce number increases the height decreases/negative correlation (1) non-linear (1)	allow not in even steps / not proportional / not a straight line height/it (nearly) halves each time scores 2 marks	(2)

8.1 Energy Changes

Q10.

Question number	Indicative content	Mark
	<p>Answers will be credited according to candidate's deployment of knowledge and understanding of the material in relation to the qualities and skills outlined in the generic mark scheme.</p> <p>The indicative content below is not prescriptive and candidates are not required to include all the material which is indicated as relevant. Additional content included in the response must be scientific and relevant.</p> <ul style="list-style-type: none"> • Chemical energy stored in battery • Transferred to KE in motors • Transferred to GPE as it rises • Thermal energy wasted (at each stage) • Energy transferred to surroundings (at each stage) 	(6)

Level	Mark	Descriptor
	0	<ul style="list-style-type: none"> • No rewardable material.
Level 1	1-2	<ul style="list-style-type: none"> • Demonstrates elements of physics understanding, some of which is inaccurate. Understanding of scientific ideas lacks detail. (AO1) • Presents an explanation with some structure and coherence. (AO1)
Level 2	3-4	<ul style="list-style-type: none"> • Demonstrates physics understanding, which is mostly relevant but may include some inaccuracies. Understanding of scientific ideas is not fully detailed and/or developed. (AO1) • Presents an explanation that has a structure which is mostly clear, coherent and logical. (AO1)
Level 3	5-6	<ul style="list-style-type: none"> • Demonstrates accurate and relevant physics understanding throughout. Understanding of the scientific ideas is detailed and fully developed. (AO1) • Presents an explanation that has a well-developed structure which is clear, coherent and logical. (AO1)

8.1 Energy Changes

Level	Mark	Additional Guidance	General additional guidance – the decision within levels e.g. - At each level, as well as content, the scientific coherency of what is stated will help place the answer at the top, or the bottom, of that level.
	0	No rewardable material.	
Level 1	1–2	<u>Additional guidance</u> Isolated fact e.g. a description of least one energy store or interpretation of diagram without mentioning energy stores or types	<u>Possible candidate responses</u> Chemical energy stored in the battery or energy transferred from the battery to the motors and then to the blades. Some energy is lost at each stage.
Level 2	3–4	<u>Additional guidance</u> Description of at least one energy transfer	<u>Possible candidate responses</u> KE (of blades) is transferred to GPE (as the drone rises) or (thermal) energy is transferred to the surroundings
Level 3	5–6	<u>Additional guidance</u> Description of two or more energy transfers	<u>Possible candidate responses</u> Chemical energy in the battery is transferred to KE of the blades AND Thermal energy is wasted in the motors when they turn.

8.1 Energy Changes

Q11.

Question Number:	Answer	Additional guidance	Mark
	<p>a description to include:</p> <p>kinetic energy (store) (of cyclist and /or bicycle) decreases / is transferred into(1)</p> <p>thermal energy (store) (of brakes / surroundings) increases (1)</p>	<p>KE for kinetic energy</p> <p>allow heat for thermal allow brakes get hotter ignore sound energy</p> <p>accept kinetic (energy) to heat (energy) for 2 marks in this context</p>	<p>(2) AO 1 1</p>

Q12.

Question number	Answer	Additional guidance	Mark
	<p>Explanation linking two from:</p> <p>choice of distance (1) 6.3 m</p> <p>(calculations of work done need) the distance moved in the direction of the force (1)</p> <p>(friction acts) along the slope / hypotenuse (1)</p>	<p>accept pushed up the slope</p>	<p>(2) AO3</p>

Q13.

Question Number:	Answer	Additional guidance	Mark
(i)	<p>0.9 (k N) (1)</p> <p>up / upwards / ascending (1)</p>	<p>accept .9 or 0.90</p> <p>north N ↑</p>	<p>(2) AO 3 2a AO 3 2b</p>

8.1 Energy Changes

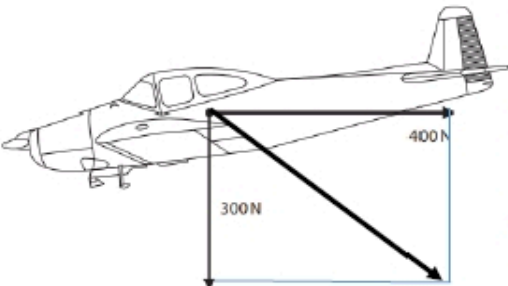
Question Number:	Answer	Additional guidance	Mark
(ii)		<p>judge length and direction by eye</p> <p>construction lines need not be shown</p> <p>magnitude need not be stated</p> <p>allow missing arrowhead if direction and length are correct</p> <p>reject answers which have any additional vectors drawn</p>	(1) AO 3 2b

Question Number:	Answer	Additional Guidance	Mark
(iii)	<p>recall and substitution (1)</p> $GPE = 750 \times 10 \times 1300$ <p>evaluation (1)</p> <p>(energy =) 9 800 000 (J)</p>	<p>no POT error (could have missed out g)</p> <p>allow answers in standard form 9.8×10^6</p> <p>allow answers that round to 9 800 000 e.g. 9 750 000 J</p> <p>allow 9800 kJ or 9.8MJ</p> <p>allow 9 555 000 J</p> <p>allow negative values</p> <p>award full marks for correct answer without working</p>	(2) AO 2 1

Q14.

Question number	Answer	Additional guidance	Mark
(i)	D R and S A, B and C are incorrect because the difference in vertical positions are all less than that shown by R and S		(1) AO1

Question number	Answer	Additional guidance	Mark
(ii)	recall (1) work done = force x distance substitution and evaluation (1) (work done =) 14,000 (J)	(work done) = 700 x 20 award full marks for the correct answer without working	(2) AO1

Question number	Answer	Additional guidance	Mark
(iii)	substitution (1) $11250 = m \times 10 \times 15$ rearrangement and evaluation (1) (mass=) 75 (kg)	 award full marks for the correct answer without working. if no other marks scored then award 1 mark for answers of 0.013 (substitution mark using $h = 15$)	(2) AO2

8.1 Energy Changes

Question number	Answer	Additional guidance	Mark
(iv)	An explanation linking some work is done to overcome friction/air resistance (1) energy is dissipated /transferred to the environment (1)	allow energy is lost thermal energy	(2) AO1

Question number	Answer	Additional guidance	Mark
(v)	C increase the efficiency of the cyclist and bicycle A is incorrect because lubrication has no effect on work done against gravity B is incorrect because lubrication will increase efficiency D is incorrect because the overall energy transfer will not increase		(1) AO1

Q15.

Question Number	Answer	Mark
	The only correct answer is B: work done= force x distance moved in direction of force A is incorrect because the equation would be dimensionally inconsistent C is incorrect because the equation would be dimensionally inconsistent D is incorrect because the direction of the distance moved is incorrect	(1)

8.1 Energy Changes

Q16.

Question Number:	Answer	Additional guidance	Mark
(i)	<p>an explanation linking:</p> <p>wheel rubs on axle (as it rotates) OR friction (between the wheel and the axle) (1)</p> <p>causes heating/transfer of (thermal) energy/ work being done (1)</p>	allow generates heat	(2) AO 1 1

Question Number:	Answer	Additional guidance	Mark
(ii)	<p>any one from:</p> <p>lubrication/oil (1)</p> <p>(ball) bearings / ball-race (1)</p> <p>go slower (1)</p>	anything that lubricates - grease etc.	(1) AO 1 1