

Magnetic Fields and Motor Effect

Questions

Q1.

A student investigates magnetism using two toys as shown in Figure 14.

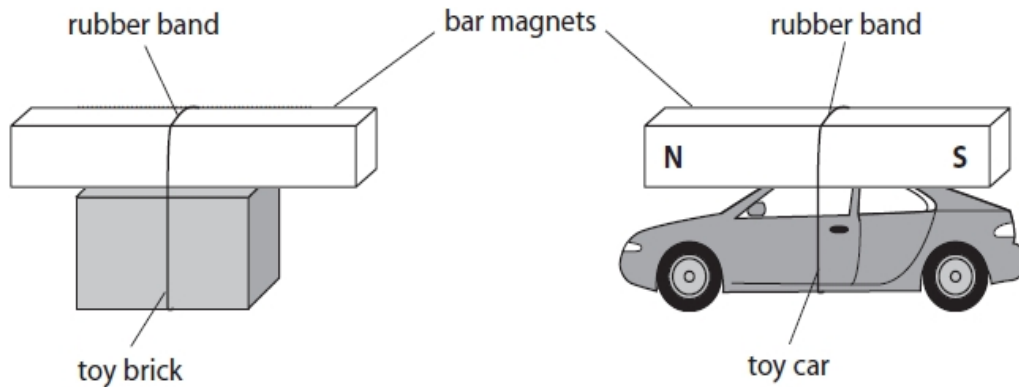

Figure 14

(i) There is a magnet attached to the top of each toy.

The student moves the toy brick towards the toy car.

The magnet on the toy brick repels the magnet on the toy car.

On Figure 14, label the north pole and the south pole on the magnet attached to the toy brick.

(1)

(ii) Explain why the toy car starts to move only when the toy brick gets near to the toy car.

(2)

.....

.....

.....

.....

12.1 Magnetic Fields and Motor Effect

(iii) The student thinks that two magnets on top of each other will produce a magnetic field that is stronger than the magnetic field from a single magnet.

The student has a metre rule and more magnets available.

Describe how the student could develop this investigation to test this theory.

(4)

.....

.....

.....

.....

.....

.....

.....

(Total for question = 7 marks)

Q2.

A student sets up the apparatus shown in Figure 9.

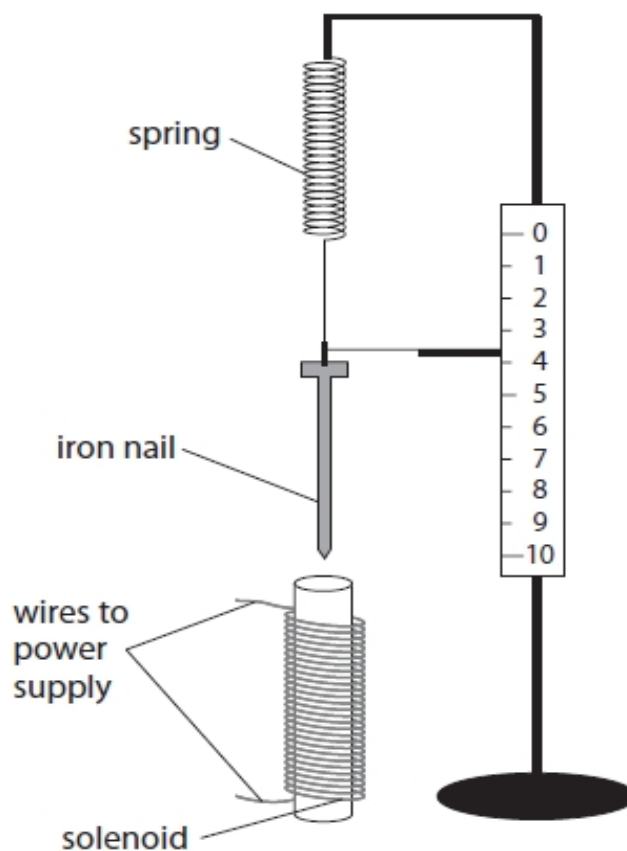

Figure 9

(i) When the current in the solenoid is switched on, the solenoid attracts the iron nail.

Describe how the student could use this apparatus to investigate how the size of the current in the solenoid affects the force of attraction between the solenoid and the iron nail.

(4)

.....

.....

.....

.....

.....

.....

.....

.....

(ii) The spring constant of a different spring is 24 N/m.

The spring is extended from its unstretched length by 12 cm.
 Calculate the energy transferred in extending the spring by 12 cm.
 Use an equation selected from the list of equations at the end of this paper.

(2)

energy transferred = J

(Total for question = 6 marks)

Q3.

Two long, thin magnets are held with their N-poles facing each other.
 The force, F , between the magnets can be calculated using the equation

$$F = \frac{K}{d^2}$$

where

K is a constant value
 d is the distance between the magnets.

(i) The magnets are 4.0 cm apart.

The force between the magnets is 1.2 N.
 Calculate the value of K .
 State the unit.

(3)

$K =$ unit

(ii) The magnets are held the same distance apart but with the N-pole of one magnet now facing the S-pole of the other magnet.

The value of K does not change.

State how the force would compare with the force in part (i).

(1)

.....

(Total for question = 4 marks)

Q4.

A student investigates moments of forces.

Figure 14 shows the apparatus used.

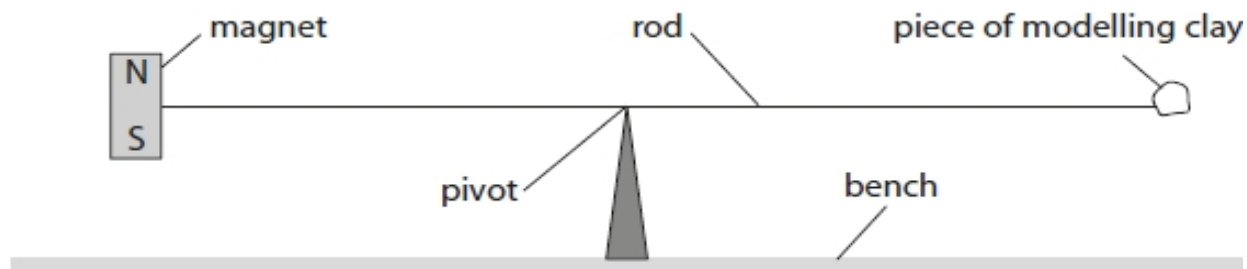

Figure 14

The pivot is under the centre of the rod. A magnet is fixed to one end of the rod. A piece of modelling clay is fixed to the other end of the rod. The system is in equilibrium. (a) The student fixes a coil to the bench under the magnet as shown in Figure 15.

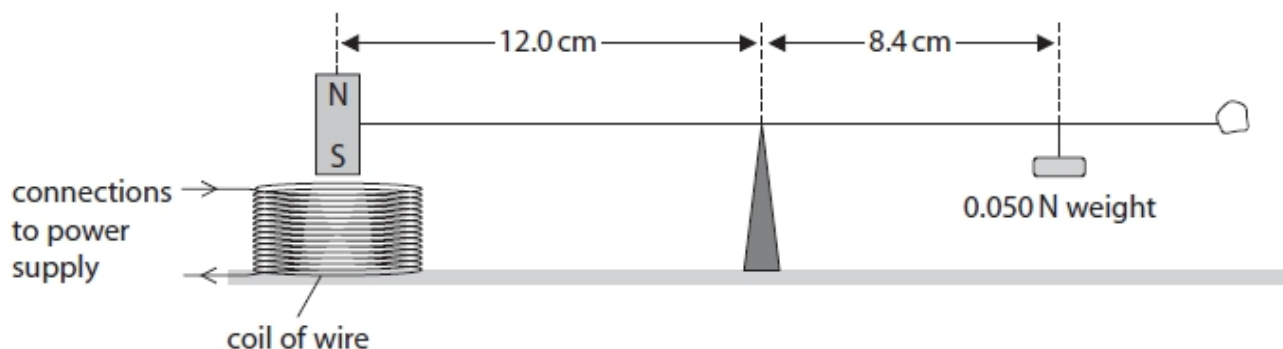

Figure 15

The coil of wire is connected to a d.c. power supply so that there is a current in the coil. To bring the system back into equilibrium, the student hangs a 0.050 N weight on the rod, 8.4 cm away from the pivot, as shown in Figure 15. Calculate the size of the force between the magnet and the coil.

(3)

force = N

(b) Describe how the student could develop the investigation to determine if the size of the force between the magnet and the coil is directly proportional to the size of the current in the coil.

(4)

.....

.....

.....

.....

.....

.....

.....

.....

(Total for question = 7 marks)

Q5.

Figure 13 shows two metal rods carrying a current.

A metal roller touches both rods and completes the circuit.

The roller is in the magnetic field produced by a magnet.

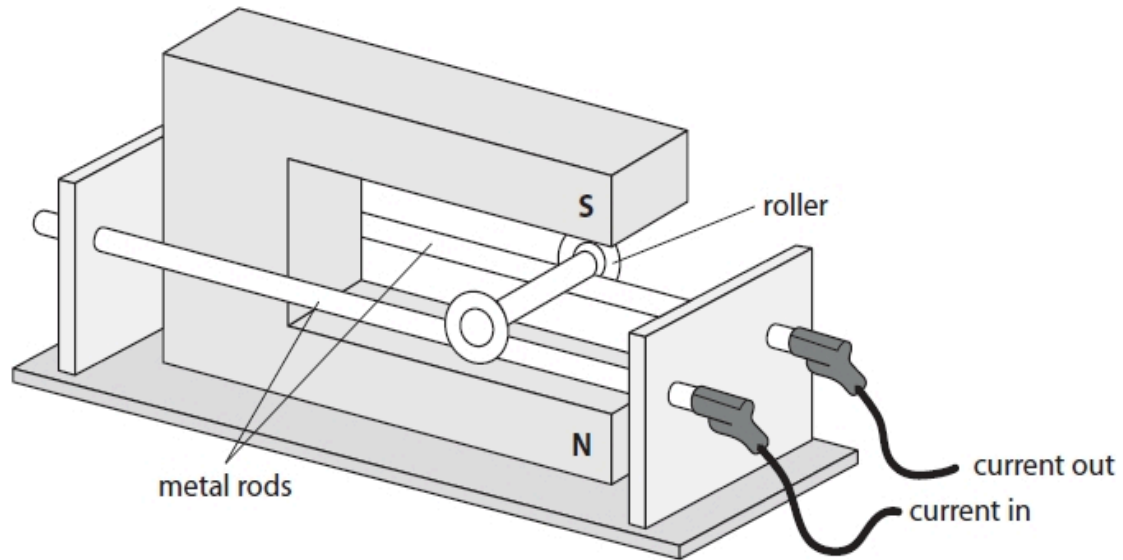

Figure 13

(i) The magnetic flux density of the magnetic field at the roller is 1.2 T.

The current in the roller is 2.5 A.

The length of the roller carrying the current is 0.060 m.

Calculate the force on the roller.

Use the equation

$$F = B \times I \times l$$

(2)

force on the roller = N

12.1 Magnetic Fields and Motor Effect

(ii) Describe how Fleming's left-hand rule can be used to determine the direction of the force acting on the roller.

You may draw a diagram to help your answer.

(3)

.....

.....

.....

.....

.....

.....

(iii) Draw an arrow on Figure 13 to show the direction of the force acting on the roller.

(1)

(Total for question = 6 marks)

Q6.

A student has

- a power pack
- a long piece of wire
- a stiff card
- iron filings

Describe how the student could use this equipment to show the shape of the magnetic field produced by a current in the wire.

You may draw a diagram to help with your answer.

(4)

.....

.....

.....

.....

.....

.....

.....

.....

(Total for question = 4 marks)

Q7.

A student measures the strength of the magnetic field at several distances from the wire in Figure 7.

Figure 8 shows most of the student's results.

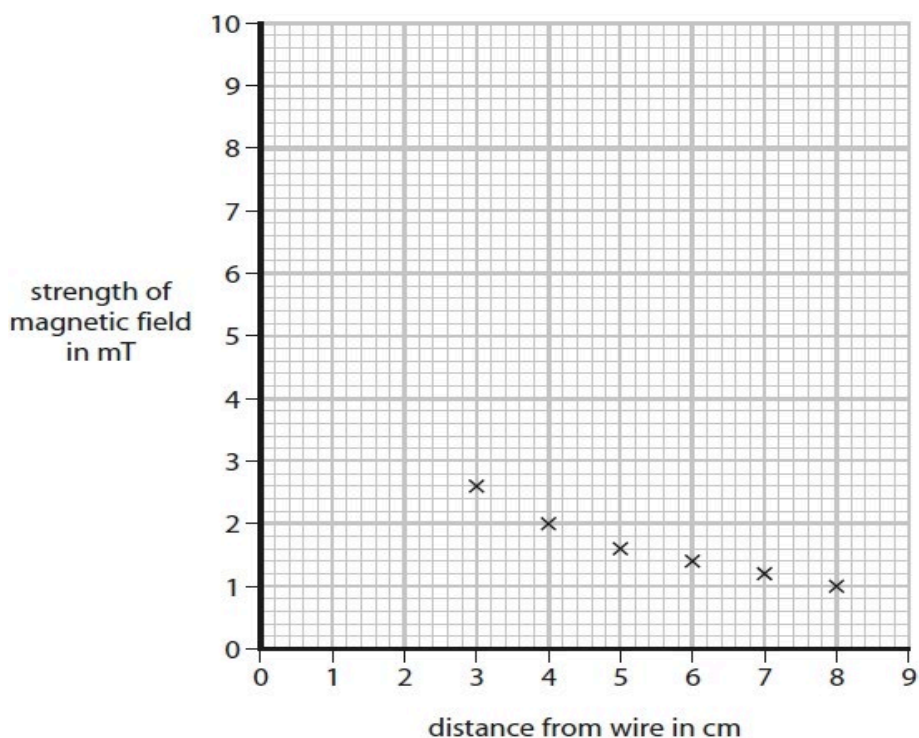

Figure 8

Figure 9 shows two extra sets of results. mT is a unit of strength of a magnetic field.

distance from wire in cm	strength of magnetic field in mT
1.0	8.1
2.0	3.9

Figure 9

(i) Plot the two extra points on Figure 8.

(2)

(ii) Draw a best fit curve on the graph in Figure 8.

(1)

(iii) Use the graph in Figure 8 to calculate the change in strength of magnetic field when the distance from the wire changes from 4 cm to 8 cm.

(2)

change in strength of magnetic field = mT)

(iv) The distance from the wire affects the strength of the magnetic field.

State one other factor that affects the strength of the magnetic field.

(1)

.....

(Total for question = 6 marks)

Q8.

Figure 7 shows a wire passing through a piece of card.

The wire carries an electric current.

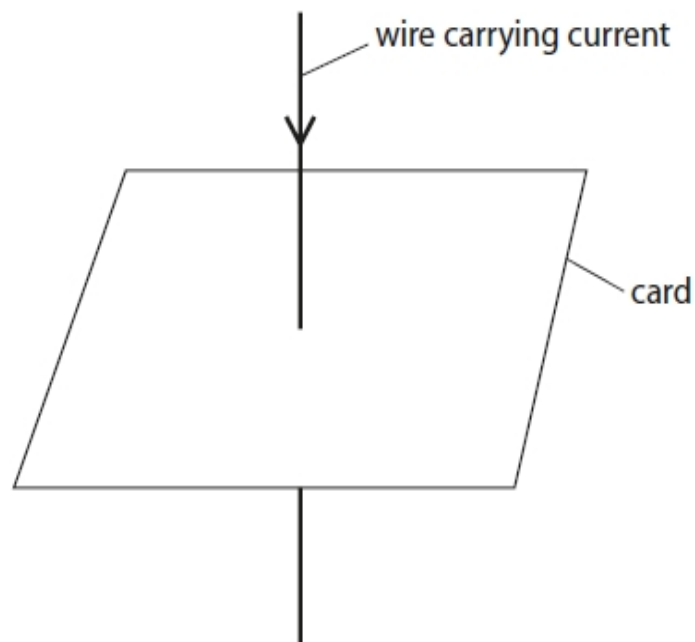

Figure 7

(i) Draw one magnetic field line on Figure 7, to show the shape of the magnetic field produced by the current.

(1)

(ii) Draw one arrow on the field line you have drawn to show the direction of the magnetic field.

(1)

(Total for question = 2 marks)

Q9.

Figure 5 shows two magnetic poles facing each other. The magnetic field between the poles is uniform.

On Figure 5, draw the magnetic field lines between the two poles and show the direction of this magnetic field.

(3)

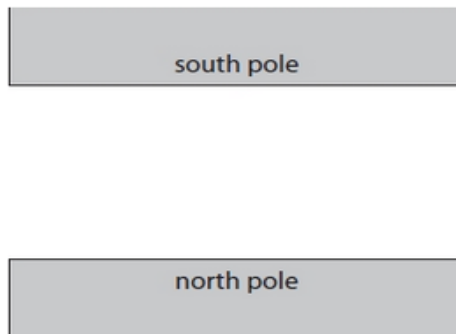

Figure 5

(Total for question = 3 marks)

Q10.

Figure 12 shows a wire carrying a current.

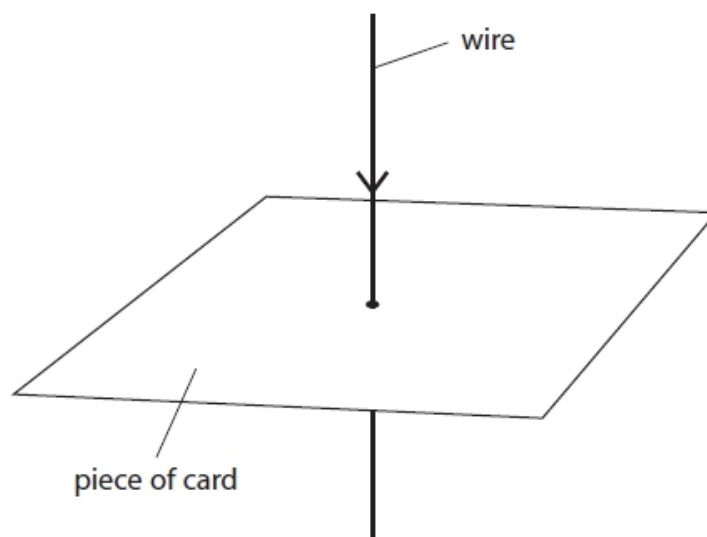

Figure 12

Draw, on the card in Figure 12, the magnetic field that is produced by the current.

(2)
(Total for question = 2 marks)

Q11.

Figure 13 shows a part of a machine used to separate steel cans from aluminium cans.

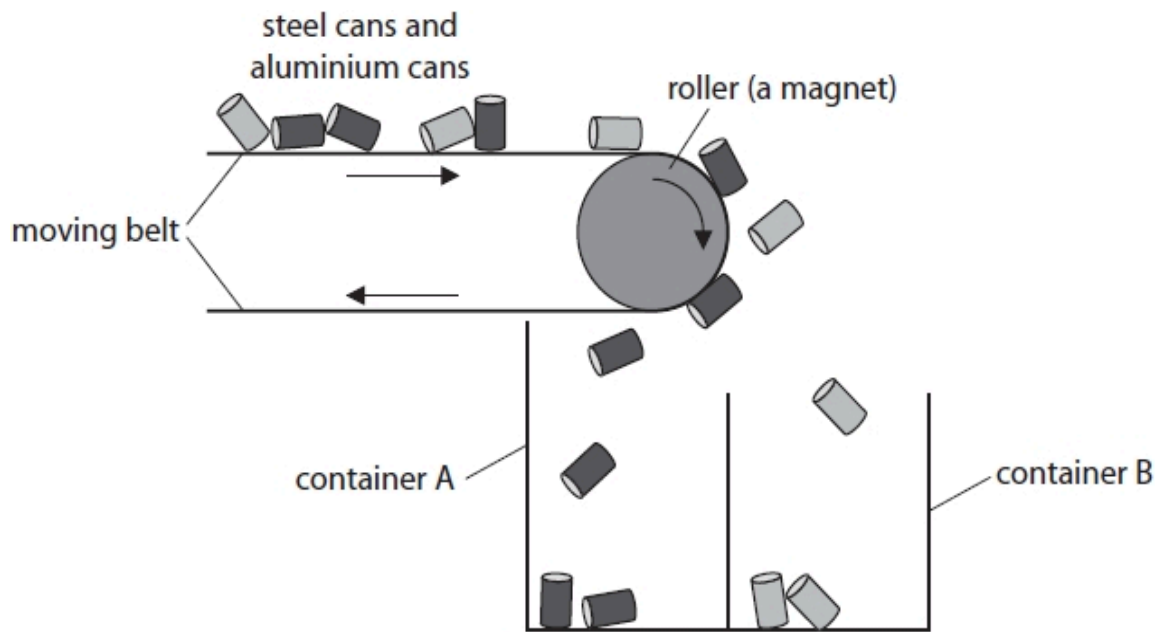

Figure 13

The cans are carried along a moving belt.

The belt goes around a roller.

The roller is a magnet.

Each can falls into one of the containers.

Explain how this machine separates the steel cans from the aluminium cans.

(2)

.....

.....

.....

.....

(Total for question = 2 marks)

Q12.

Figure 6 shows some objects and words describing these objects.

Draw one line from each object to its description.

(2)



object	description
 <p>nail in a current-carrying coil</p>	<input type="checkbox"/> non-magnetic
 <p>plotting compass needle</p>	<input type="checkbox"/> permanent magnet
 <p>wooden ruler</p>	<input type="checkbox"/> temporary magnet

Figure 6

(Total for question = 2 marks)

Q13.

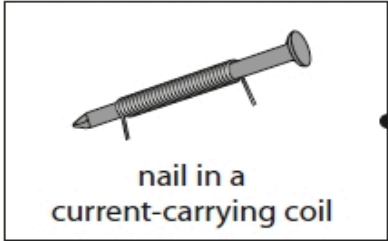
Figure 11 shows a copper wire between two magnetic poles.

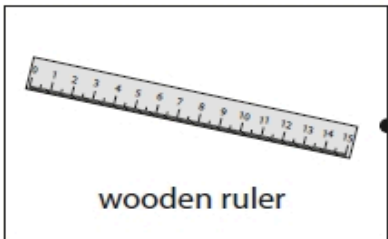
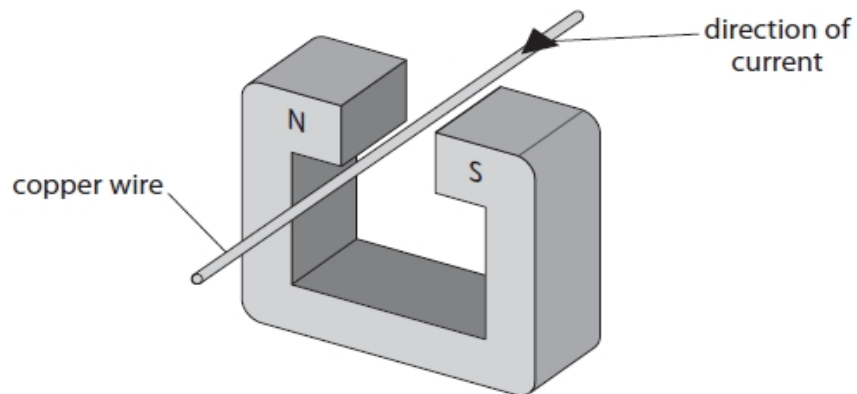

Figure 11

The current in the wire is in the direction shown by the arrow.

The wire experiences a force due to the magnetic field.

(i) The direction of the force due to the magnetic field is

(1)

- A down
- B up
- C towards the north pole of the magnet
- D towards the south pole of the magnet

(ii) The interaction between the magnetic fields produced by the magnet and the current in the wire produces forces on the magnet and the wire. Compare these two forces.

(1)

.....

.....

(iii) Figure 12 shows a different wire inside a uniform magnetic field.

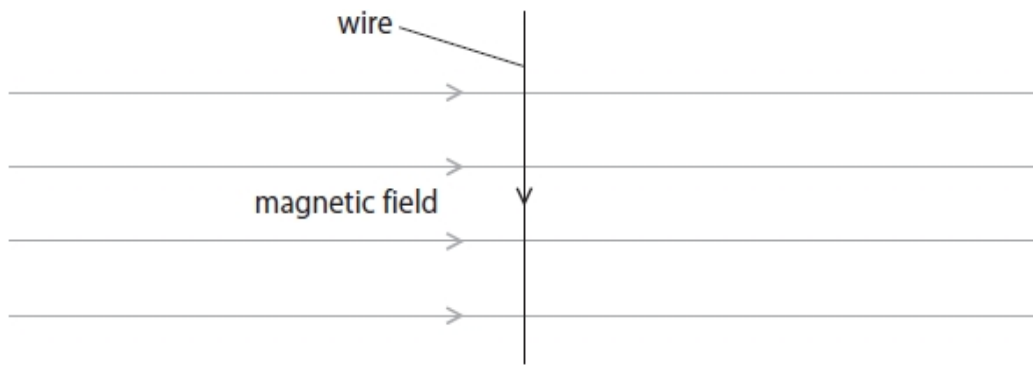

Figure 12

The magnetic flux density of the magnetic field is 0.72 N/A m .
 The length of the wire inside the field is 30 mm .
 The size of the force due to the magnetic field on the wire is 0.045 N .

Calculate the size of the current in the wire.

Use an equation selected from the list of equations at the end of this paper.

(3)

current in the wire = A

(Total for question = 5 marks)

Q14.

Which of these is a magnetic material?

(1)

- A aluminium
- B carbon
- C cobalt
- D copper

(Total for question = 1 mark)

Q15.

Figure 11 shows the magnetic field of a magnet.

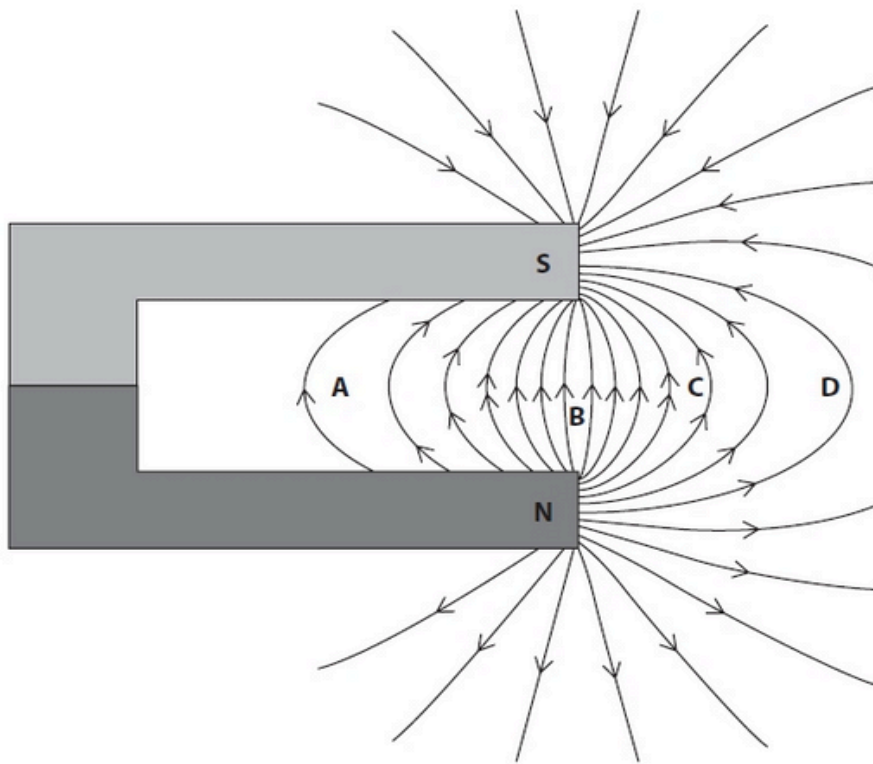

Figure 11

At which point is the magnetic field strongest?

(1)

- A
- B
- C
- D

(Total for question = 1 mark)

Q16.

A student uses a plotting compass to investigate the magnetic field around a wire.

Figure 10 shows the wire going straight through a card.

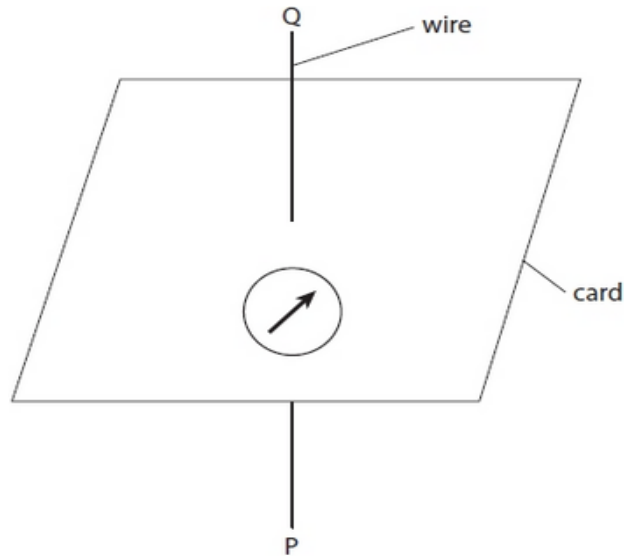

Figure 10

Figure 10 shows the compass needle when there is no current in the wire.

(i) Which of these shows a possible direction of the compass needle when there is a current in the wire going from P to Q?

(1)



(ii) Describe how the student could develop the investigation to find the shape of the magnetic field produced by the current.

(3)

.....

.....

.....

.....

.....

.....

(Total for question = 4 marks)

Q17.

A student uses plotting compasses to investigate the magnetic field between the poles of two bar magnets.

Figure 12 shows one of the plotting compasses and one of the bar magnets.



Figure 12

The student places the two magnets on a piece of paper with a pole of one magnet a few centimetres away from a pole of the other magnet. The student places 20 plotting compasses on the paper near the magnets. Figure 13 shows the direction in which each of the plotting compasses points.

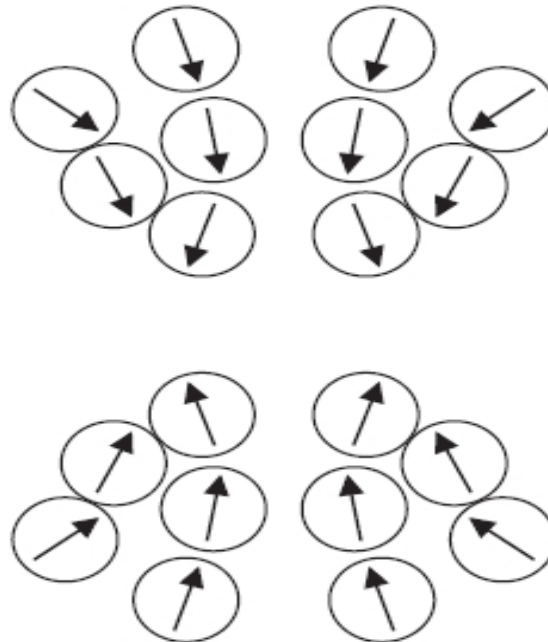

Figure 13

- (i) Draw two rectangles on Figure 13 to show the positions of the two bar magnets. Label the N-pole and the S-pole of each magnet.

(2)

(ii) The student wants to determine the shape of the magnetic field for a larger area around the magnets.

Describe how the student should continue the investigation using just one plotting compass.

(3)

.....

.....

.....

.....

.....

.....

(Total for question = 5 marks)

Q18.

Figure 4 shows the magnetic field produced by a current in a long, straight wire.

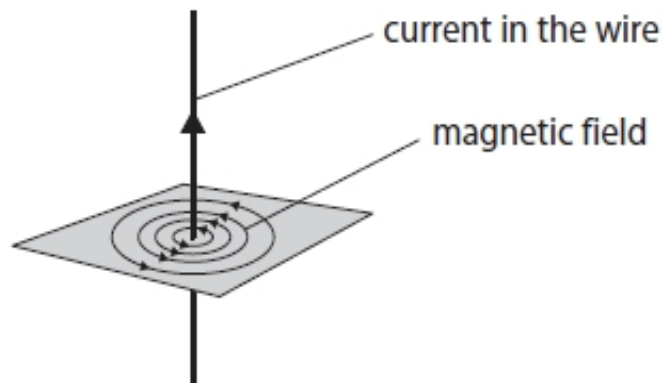

Figure 4

Which row of the table is correct when the strength of the magnetic field is greatest?

(1)

	distance from the wire	current
<input checked="" type="checkbox"/> A	small	small
<input checked="" type="checkbox"/> B	small	large
<input checked="" type="checkbox"/> C	large	small
<input checked="" type="checkbox"/> D	large	large

(Total for question = 1 mark)

Q19.

Figure 5 shows a magnet holding some paper clips.

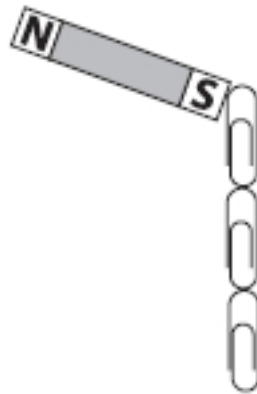

Figure 5

Describe how a student could show that the paper clips are induced magnets.

(2)

.....

.....

.....

.....

(Total for question = 2 marks)

Q20.

Describe how you could show that the Earth has a magnetic field.

(2)

.....

.....

.....

.....

(Total for question = 2 marks)

Q21.

A student investigates moments of forces.

Figure 14 shows the apparatus used.

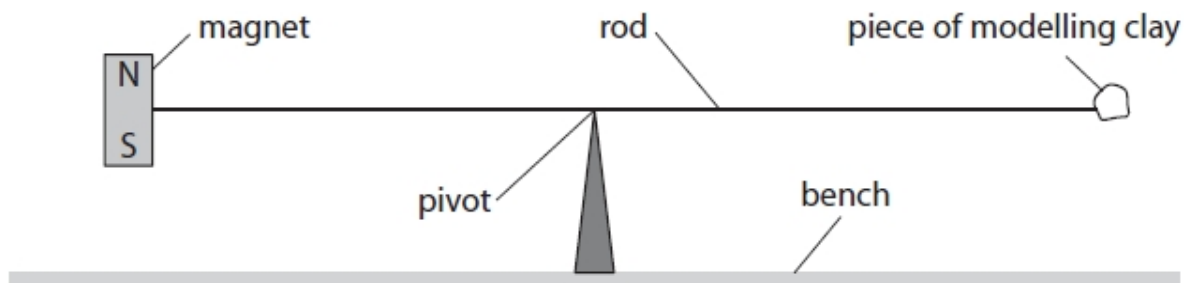

Figure 14

The pivot is under the centre of the rod.

A magnet is fixed to one end of the rod.

A piece of modelling clay is fixed to the other end of the rod.

The system is in equilibrium.

State the relationship between the moment of the weight of the magnet and the moment of the weight of the piece of modelling clay about the pivot.

(1)

.....

.....

(Total for question = 1 mark)

Q22.

Which of these materials would be the most suitable for making a temporary magnet?

(1)

- A copper
- B iron
- C plastic
- D steel

(Total for question = 1 mark)

Q23.

A student has a bar magnet, a piece of iron the same size as the magnet, and some paper clips.

Describe how the student could use these items to demonstrate temporary induced magnetism.

(3)

.....

.....

.....

.....

.....

.....

(Total for question = 3 marks)

Q24.

A student uses a compass to investigate the magnetic field near a bar magnet.

The student places the compass near the bar magnet as shown in Figure 6.



Figure 6

(i) Mark the north pole of the bar magnet with an 'N' in Figure 6.

(1)

(ii) State two ways in which the investigation could be developed to show the shape of the magnetic field around the bar magnet.

You may add to Figure 6 to help with your answer.

(2)

1

.....

2

.....

(Total for question = 3 marks)



Mark Scheme – Magnetic Fields and Motor Effect

Q1.

Question number	Answer	Additional guidance	Mark
(i)	<div style="border: 1px solid black; padding: 5px; display: inline-block;"> S N </div>	allow <div style="border: 1px solid black; padding: 2px; display: inline-block; margin: 5px 0;">s</div> OR <div style="border: 1px solid black; padding: 2px; display: inline-block; margin: 5px 0;">south north</div>	(1)
Question number	Answer	Additional guidance	Mark
(ii)	an explanation linking two from (strength of magnetic) field /force (1) (depends on) distance from the magnet (1)	(magnets) attract / repel force / field is weaker when further away (from magnet) or reverse argument lines of force are further apart	(2)
Question number	Answer	Additional guidance	Mark
(iii)	a description to include four from move brick towards the car (1) until car (just) starts to move (1) measure distance of brick from car/magnet (1) repeat with 2 magnets (1) compare distances (for one magnet and for two magnets) (1) detail about procedure (1) conclusion or prediction (1)	change distance between car and brick measure how close car gets to the brick how to attach second magnet(s) how to measure distance where to measure take several readings and find average if distance is bigger then it works	(4)

Q2.

Question Number:	Answer	Additional Guidance	Mark
(i)	<p>a description to include 4 of the following:</p> <ul style="list-style-type: none"> • note position of pointer before current is switched on (1) • measure position of pointer when current in coil (1) • (use an ammeter to) measure current (1) • calculate the extension / stretch of the spring (1) • use force (of attraction) is proportional to extension / stretch (of spring) (1) • repeat with different currents (1) 	<p>measure length of spring before current is switched on</p> <p>how far nail moves</p> <p>calculate force from spring constant and extension</p> <p>calibrate spring</p> <p>increase the current</p> <p>calculate the extension of the spring using new position of pointer minus starting position of pointer is worth 3 marks</p>	(4) AO 2 2

Question Number:	Answer	Additional Guidance	Mark
(ii)	<p>select and substitute (1)</p> <p>(E =) $\frac{1}{2} \times 24 \times 0.12^2$</p> <p>evaluation (1)</p> <p>(E =) 0.17 (J)</p>	<p>$\frac{1}{2} \times 24 \times 12^2$ max 1 mark</p> <p>accept answers that round down to 0.17 e.g. 0.1728</p> <p>POT error (e.g. 1728) max 1 mark</p> <p>award full marks for correct answer without working</p>	(2) AO 2 1

Q3.

Question number	Answer	Additional guidance	Mark
(i)	substitution of values (1) $1.2 = \frac{K}{4(.0)^2}$ rearrangement and evaluation (1) (K=) 19 unit (1) N cm ²	allow rearrangement before substitution (K=) $1.2 \times 4(.0)^2$ 19.2 0.00192 award full marks for the correct answer without working independent mark N m ²	(3) AO2

Question number	Answer	Additional guidance	Mark
(ii)	same magnitude and opposite direction (1)	allow (now) attraction for opposite direction	(1) AO1

Q4.

Question number	Answer	Additional guidance	Mark
a	<p>recall and substitution (1)</p> <p>(force x 12.0 =) 0.050 x 8.4</p> <p>rearrangement (1)</p> <p>(force =) $\frac{0.050 \times 8.4}{12.0}$</p> <p>evaluation (1)</p> <p>(force =) 0.035 (N)</p>	<p>allow substitution and rearrangement in either order</p> <p>award full marks for the correct answer without working.</p> <p>if no other marks scored then award 1 mark for answers that round to 29 (eg 28.57) (substitution mark)</p>	(3) AO2

Question number	Answer	Additional guidance	Mark
b	<p>a description to include four of the following</p> <p>measure the value of current (1)</p> <p>measure force or distance(1)</p> <p>vary the current (1)</p> <p>restore equilibrium of system (1)</p> <p>calculate ratio between force and current or distance and current (1)</p> <p>if ratio is the same then they are proportional (1)</p>	<p>accept calculate for measure</p> <p>increase weight or move (existing) weight to new position</p> <p>plot a graph of force / distance against current</p> <p>graph would be a straight line (through the origin)</p>	(4) AO3

Q5.

Question number	Answer	Additional guidance	Mark
i	substitution (1) ($F = $) $1.2 \times 2.5 \times 0.06$ evaluation (1) 0.18 (N)	award full marks for the correct answer without working	(2)

Question number	Answer	Additional guidance	Mark
(ii)	a description to include first finger, second finger and thumb (of left-hand) held mutually perpendicular (1) first finger (is in the direction of) magnetic field OR second finger (is in the) direction of) current (1) thumb (is in the) direction of force / motion (1)	award 1 mark for attempt at mutually perpendicular shown in a diagram diagram relating thumb and fingers to correct quantities at right angle gains 3 marks	(3)

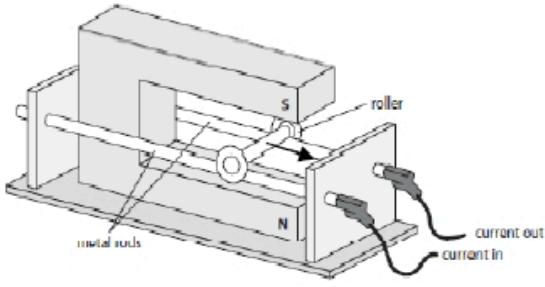
Question number	Answer	Additional guidance	Mark
(iii)	 <p>arrow from roller towards contacts (1)</p>		(1)

Q6.

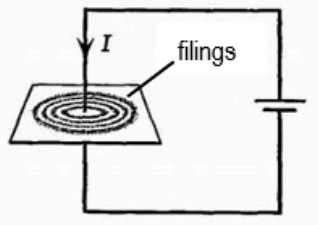
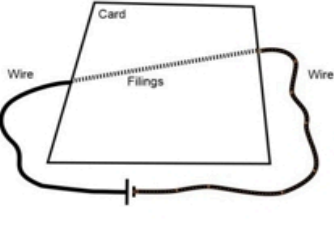
Question Number	Answer	Additional guidance	Mark
	<p>An answer that combines four of the following points.</p> <p>MP1: Put wire {through card / near card / under card / over card / round rolled up card } (1)</p> <p>MP2: Put iron filings on card / around wire (1)</p> <p>MP3: Connect wire to power pack One wire is acceptable (1)</p> <p>MP4: Switch on or reference to current / charges flowing (in wire) NOT in filings (1)</p> <p>MP5: Filings attracted / moving / see if wire attracts filings (1)</p> <p>MP6: Pattern seen in filings – circles / lines / onion (1)</p>	<p>IGNORE use of apparatus not specified in the list (Iron nails etc)</p>   <p>marking points can be scored from a diagram</p> <p>filings show shape of field</p>	(4)

Q7.

Question number	Answer	Additional guidance	Mark
i	<p>One mark for each point plotted correctly, to within ± 1 small square</p>		(2) AO2

Question number	Answer	Additional guidance	Mark
ii	smooth curve drawn fitting the plotted points (1)	judge by eye	(1) AO2

Question number	Answer	Additional guidance	Mark
iii	substitution using an attempt at calculation – any subtraction seen (1) e.g. $2(.0) - 1(.0)$ evaluation (1) (-) $1(.0)$ (mT)	accept any number that rounds to 1.0 award full marks for correct answer without working	(2) AO3

Question number	Answer	Mark
iv	(size of) current	(1) AO1

Q8.

Question number	Answer	Additional guidance	Mark
i	circle shown around wire (1)	allow tolerance for translation of 3D to 2D ignore any multiplicity of those circles	(1) AO1

Question number	Answer	Additional guidance	Mark
ii	arrow indicating a clockwise direction (for magnetic field line drawn for i) (1)		(1) AO1

Q9.

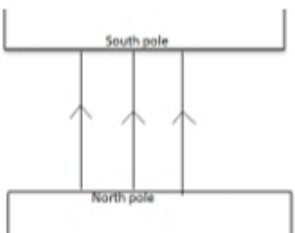
Question Number	Answer	Additional guidance	Mark
	 <p>MP1: any (vertical) line from pole to pole (1)</p> <p>MP2: at least two further equidistant straight, (vertical) lines from pole to pole (1)</p> <p>MP3: arrow on any line, north to south (1)</p>	<p>ignore lines outside of the magnets for MP1 and MP2</p> <p>judge by eye</p> <p>any arrow south to north, no mark awarded for MP3</p>	(3)

12.1 Magnetic Fields and Motor Effect

Q10.

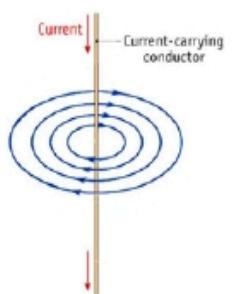
Question number	Answer	Additional guidance	Mark
	 <p>at least two concentric circles (1)</p> <p>arrows correct (1)</p>	<p>separation of the circles is increasing</p>	(2)

Q11.

Question number	Answer	Additional guidance	Mark
	<p>an explanation linking any two of</p> <p>steel is magnetic (material) (1)</p> <p>aluminium is non-magnetic (material) (1)</p> <p>steel falls into container A / aluminium falls into container B (1)</p>	<p>steel attracted / sticks to / carried round by magnet/roller)</p> <p>is not attracted / does not stick (to magnet roller)</p> <p>steel cans are carried further round than aluminium and fall into A steel hangs on for longer / aluminium falls quicker</p>	(2)

12.1 Magnetic Fields and Motor Effect

Q12.

Question number	Answer	Additional guidance	Mark
		<p>three links correct (2)</p> <p>one link correct (1)</p>	(2) AO1

Q13.

Question Number	Answer	Additional guidance	Mark
(i)	<p>The only correct answer is B: up</p> <p>A is incorrect because it does not follow the “Left Hand Rule”</p> <p>C is incorrect because it is not perpendicular to the direction of the magnetic field.</p> <p>D is incorrect because it is not perpendicular to the direction of the magnetic field.</p>		(1)

Question Number	Answer	Additional guidance	Mark
(ii)	<p>A description that includes:</p> <p>(forces are) equal (in size) and opposite (in direction)</p>	<p>accept (in this context) forces balance</p>	(1)

12.1 Magnetic Fields and Motor Effect

Question Number	Answer	Additional guidance	Mark
(iii)	substitution into $F = B \times I \times l$ (1) $0.045 = 0.72 \times I \times 30 (\times 10^{-3})$ rearrangement (1) $(I =) \frac{F}{B \times l}$ OR $\frac{0.045}{0.72 \times 30 (\times 10^{-3})}$ evaluation (1) 2.1 (A)	rearrangement and substitution can be in either order $(I =) \frac{45}{21.6}$ accept answers that round to 2.1 (A) accept final value rounded down to 2 leave POT until final evaluation award full marks for the correct answer without working	(3)

Q14.

Question Number	Answer	Mark
	C cobalt C is the only correct answer. A is incorrect because aluminium is not magnetic. B is incorrect because carbon is not magnetic. D is incorrect because copper is not magnetic.	(1)

Q15.

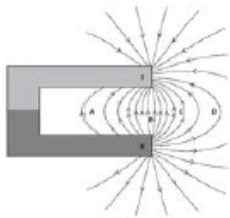
Question number	Answer	Mark
	<p>B</p>  <p>A,C and D are in the areas where the field lines are further apart and the field is weaker</p>	(1)

Q16.

Question Number	Answer	Mark
(i)	<p>The only correct answer is A</p>  <p>B is incorrect because it is not tangential to the (circular) magnetic field lines produced by the current</p> <p>C is incorrect because it is not tangential to the (circular) magnetic field lines produced by the current</p> <p>D is incorrect because it is not tangential to the (circular) magnetic field lines produced by the current</p>	(1)

12.1 Magnetic Fields and Motor Effect

Question Number	Answer	Additional guidance	Mark
(ii)	<p>A description of the method that includes:</p> <p>EITHER (using single compass)</p> <p>record field at one location (1)</p> <p>find how field continues (1)</p> <p>connect the dots (to reveal overall shape of field / line) (1)</p> <p>OR</p> <p>arrange multiple compasses (1)</p> <p>over all of the card (1)</p> <p>direction of (all of) the compass needles indicates shape of field (1)</p>	<p>Marking points may be awarded from a diagram.</p> <p>mark where compass points or put dots at each end of needle / arrow</p> <p>move compass to new position / until needle over previous dot</p> <p>start from different position and repeat (idea of obtaining concentric circles)</p> <p>all the way round the wire</p>	(3)
	<p>OR</p> <p>sprinkle iron filings on card (before current is switched on) (1)</p> <p>switch on current/ tap card (1)</p> <p>pattern produced indicates shape of field (1)</p>	<p>allow iron filings to arrange themselves</p>	

Q17.

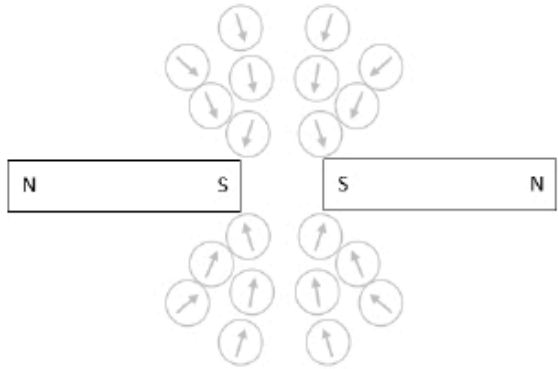
Question number	Answer	Additional guidance	Mark
(i)	<p>example:</p>  <p>rectangles in (approximately) correct position (1)</p> <p>all four poles correctly labelled (1)</p>	<p>judge by eye but do not allow rectangles in contact</p>	(2) AO3

Question number	Answer	Additional guidance	Mark
(ii)	<p>a description to include</p> <p>place a (plotting) compass on the paper (near to the magnet(s)) and mark direction of the field (at that point) (1)</p> <p>determine how the field continues from that point (1)</p> <p>connect field lines to reveal overall shape(1)</p>	<p>place a (plotting) compass on the paper (near to the magnet(s)) and put a dot at each end of the needle</p> <p>move compass so that one end of the needle is over the mark (just made)</p> <p>join up the dots</p>	(3) AO1

Q18.

Question Number:	Answer	Mark
	<p>B small large</p> <p>The only correct answer is B</p> <p><i>A is not correct because the current is small</i></p> <p><i>C is not correct because the distance from the wire is large</i></p> <p><i>D is not correct because the distance from the wire is large</i></p>	<p>(1) AO 1 1</p>

Q19.

Question Number:	Answer	Additional guidance	Mark
	<p>a description to include:</p> <p>remove the magnet (from the paper clips)(1)</p> <p>paperclips no longer attracted to each other (1)</p>	<p>accept no longer magnetic</p>	<p>(2) AO 3 1a AO 3 1b</p>

Q20.

Question Number:	Answer	Additional guidance	Mark
	<p>a description to include:</p> <p>use a compass (1)</p> <p>always points in the same direction / will point north (1)</p>	<p>accept reasonable alternatives such as suspended magnet needles on cork in water</p>	<p>(2) AO 3 2a</p>

Q21.

Question number	Answer	Additional guidance	Mark
	(sum of) the clockwise moments = (sum of) the anticlockwise moments	moment of magnet = moment of modelling clay moments are equal (size)	(1) AO1

Q22.

Question Number:	Answer	Mark
	<p>B iron</p> <p>The only correct answer is B</p> <p><i>A is not correct as copper is non-magnetic</i> <i>C is not correct as plastic is non-magnetic</i> <i>D is incorrect, as steel is only suitable for a permanent magnet</i></p>	(1) AO 1 1

Q23.

Question Number:	Answer	Additional Guidance	Mark
	<p>a description to include:</p> <p>method of producing temporary induced magnetism (1)</p> <p>method of demonstrating the magnetic properties of the temporary magnet (1)</p> <p>method of demonstrating magnetic effect is temporary (1)</p>	<p>place iron near / in contact with magnet / in magnetic field</p> <p>OR</p> <p>use magnet to pick up one paper clip</p> <p>OR</p> <p>use magnet to make iron a temporary magnet</p> <p>paper clip(s) attracted to iron</p> <p>OR</p> <p>use first paper clip to pick up another paper clip</p> <p>remove magnet and paper clips no longer attracted / fall off</p> <p>OR</p> <p>wait some / short time and iron bar no longer picks up / attracts paper clips</p>	<p>(3) AO 1 2</p>

Q24.

Question Number:	Answer	Additional guidance	Mark
(i)		N must be at the end of the bar, not at the end of the compass needle	(1) AO 3 3a

Question Number:	Answer	Additional guidance	Mark
(ii)	<p>any two developments from:</p> <p>use a compass in various positions / more compasses (1)</p> <p>plot more points/mark direction of compass(point)/ join the dots (1)</p> <p>sprinkle/add iron filings (1)</p> <p>give more than one (magnetic field) line (1)</p>	<p>marks can be taken from text or diagram</p> <p>allow 'around' 'on', 'near' the magnet etc</p> <p>series of dots / several compasses end to end</p>	(2) AO 3 3a