

GCSE BIOLOGY

Higher Tier Paper 2H

H

Specimen 2018

Time allowed: 1 hour 45 minutes

Materials

For this paper you must have:

- a ruler
- a calculator.

Instructions

- Answer all questions in the spaces provided.
- Do all rough work in this book. Cross through any work you do not want to be marked.

Information

- There are 100 marks available on this paper.
- The marks for questions are shown in brackets.
- You are expected to use a calculator where appropriate.
- You are reminded of the need for good English and clear presentation in your answers.
- When answering questions 01.3, 02.4, 03.3, 04.2 and 08.2 you need to make sure that your answer:
 - is clear, logical, sensibly structured
 - fully meets the requirements of the question
 - shows that each separate point or step supports the overall answer.

Advice

In all calculations, show clearly how you work out your answer.

Please write clearly, in block capitals, to allow character computer recognition.

Centre number Candidate number

Surname

Forename(s)

Candidate signature

0	1
---	---

Charles Darwin proposed the theory of natural selection.

Many people at the time did not accept his theory.

0	1
---	---

.	1
---	---

There was a different theory at the same time as Darwin's theory.

The different theory said that changes in an organism during its life could be inherited.

Who proposed this theory?

[1 mark]

0 1 . 2

Studying fossils helps scientists understand how living things have evolved.

Figure 1 shows a fossilised snake.

Figure 1



Explain how the fossil in Figure 1 may have formed.



[3 marks]

Question 1 continues on the next page

There are many types of rat snake in the world.

Table 1 shows two types of rat snake

Table 1

		
Type of snake	Japanese rat snake	Texas rat snake
Colour of snake	Green	Pale brown
Type of environment	Grass	Dry and dusty

0 1 . 3

The different types of rat snake have evolved from similar ancestors.

The rat snakes have evolved to suit their environments.

Explain how the Japanese rat snake evolved to be different from the Texas rat snake.

[4 marks]

0 1 . 4

Many species of snake have become extinct.

Give one reason why a species might become extinct.

[1 mark]

Turn over for the next question

0	2
---	---

A gardener wants to add compost to the soil to increase his yield of strawberries.

The gardener wants to make his own compost.

0	2
---	---

.	1
---	---

An airtight compost heap causes anaerobic decay.

Explain why the gardener might be against producing compost using this method.

[2 marks]

The gardener finds this research on the internet:

'A carbon to nitrogen ratio of 25:1 will produce fertile compost.'

Table 2.
Look at

Table 2

Type of material to compost	Mass of carbon in sample in g	Mass of nitrogen in sample in g	Carbon:nitrogen ratio
Chicken manure	8.75	1.25	7:1
Horse manure	10.00	0.50	20:1
Peat moss	9.80	0.20	X

0 2 . 2 Determine the ratio X in Table 2 .

[1 mark]

Ratio _____

0 2 . 3 Which type of material in Table 2 would be best for the gardener to use to make his compost?

Justify your answer.

[1 mark]

Question 2 continues on the next page

0 2 . 5

Figure 2 shows two strawberries.

- Both strawberries were picked from the same strawberry plant.
- Both strawberries were picked 3 days ago.
- The strawberries were stored in different conditions.

Figure 2

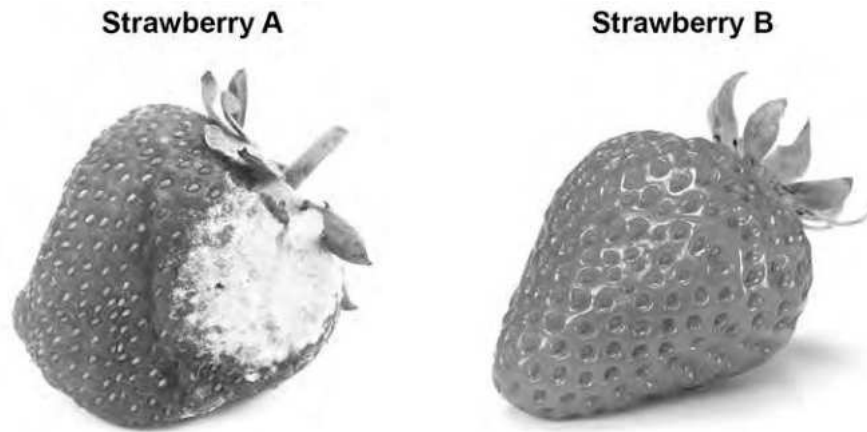

Give three possible reasons that may have caused strawberry A to decay. [3 marks]

1

2

3

Turn over for the next question

0	3
---	---

Many different types of animals are produced using selective breeding.

Some cats are selectively bred so that they do not cause allergies in people.

0	3
---	---

.

1

Suggest two other reasons why people might selectively breed cats.

[2 marks]

1 _____

2 _____

0	3
---	---

.

2

Selective breeding could cause problems of inbreeding in cats.

Describe one problem inbreeding causes.

[1 mark]

0 3 . 3

Many people have breathing problems because they are allergic to cats.

The allergy is caused by a chemical called Fel D1.

Different cats produce different amounts of Fel D1.

A cat has been bred so that it does not produce Fel D1.

The cat does not cause an allergic reaction.

Explain how the cat has been produced using selective breeding.

[4 marks]

Turn over for the next question

There are no questions printed on this page

0	4
---	---

A student plans an investigation using mould.

0	4	.	1
---	---	---	---

Mould spores are hazardous.

Give one safety precaution the student should take when doing this investigation.

[1 mark]

A student made the following hypothesis about the growth of mould:

'The higher the temperature, the faster the growth of mould'.

The student planned to measure the amount of mould growing on bread.

The student used the following materials and equipment:

- slices of bread
- sealable plastic bags
- a knife
- a chopping board
- mould spores.

0	4	.	2
---	---	---	---

Describe how the materials and equipment could be used to test the hypothesis.

[4 marks]

Question 4 continues on the next page

0 | 4 | . | 3

Give one variable the student should control in the investigation.

[1 mark]

Another student did a similar investigation.

Figure 3 shows the results.

Figure 3

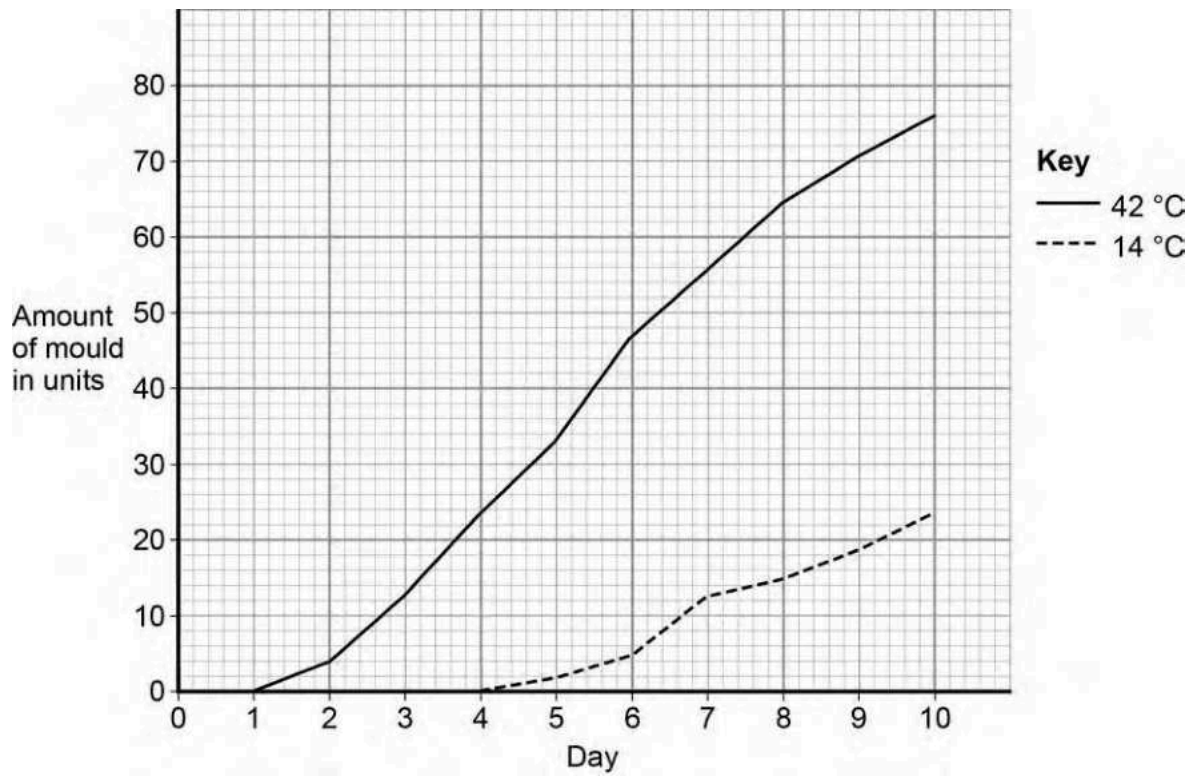

0 | 4 | . | 4

Determine the rate of mould growth at 42 °C between day 2 and day 7.

[2 marks]

Rate of mould growth =

_____ units per day

0	4	.	5
---	---	---	---

The growth of mould shows decomposition of the bread.

Give a conclusion about decomposition from the results in Figure 3 .

[1 mark]

Turn over for the next question

0 5

Figure 4 shows a reflex in the iris of the human eye in response to changes in light levels.

Figure 4

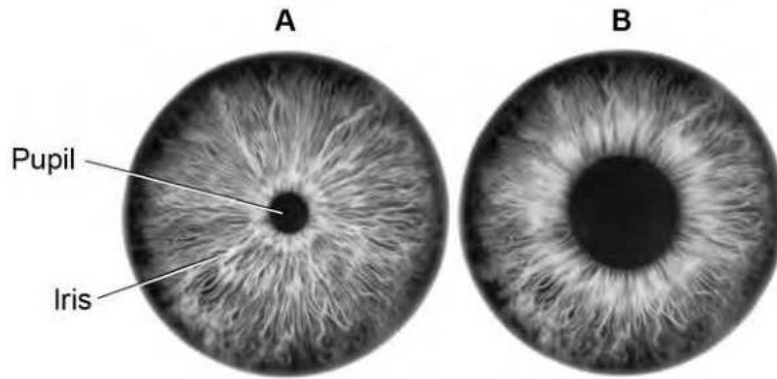

0 5

. 1

Describe the changes in the pupil and iris going from A to B in Figure 4 .

Explain how these changes occur.

Refer to the changes in light level in your answer.

[4 marks]

06

Two students investigated reflex action times.

This is the method used.

1. Student A sits with her elbow resting on the edge of a table.
2. Student B holds a ruler with the bottom of the ruler level with the thumb of Student A.
3. Student B drops the ruler.
4. Student A catches the ruler and records the distance, as shown in Figure 7 .
5. Steps 1 to 4 were then repeated.

Figure 7

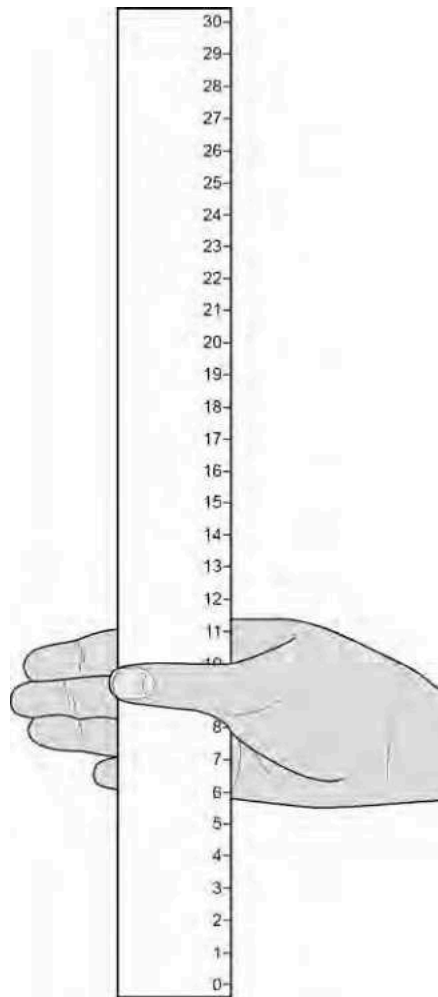

0	6	.	1
---	---	---	---

Suggest two ways the students could improve the method to make sure the test would give valid results.

[2 marks]

1 _____

2 _____

Question 6 continues on the next page

Table 3 shows Student A's results.

Table 3

Test Number	Distance ruler dropped in mm
1	117
2	120
3	115
4	106
5	123
6	125
7	106

0 6 . 2 What is the median result?

[1 mark]

Tick one box.

- 106
- 115
- 116
- 117
- 123

06 . 3

The mean distance the ruler was dropped is 116 mm.

Calculate the mean reaction time.

Use the equation:

[3 marks]

$$\text{reaction time in s} = \sqrt{\frac{\text{mean drop distance in cm}}{490}}$$

Give your answer to 3 significant figures

Mean reaction time = _____ s

06 . 4

The students then measured Student A's reaction time using a computer program.

This is the method used.

1. The computer shows a red box at the start.
2. As soon as the box turns green the student has to press a key on the keyboard as fast as possible.
3. The test is repeated five times and a mean reaction time is displayed.

Student A's mean reaction time was 110 ms.

Using a computer program to measure reaction times is likely to be more valid than the method using a dropped ruler.

Give two reasons why.

[2 marks]

1 _____

2 _____

Question 6 continues on the next page

06 . 5

A woman has a head injury.

Her symptoms include:

- finding it difficult to name familiar objects
- not being able to remember recent events.

Suggest which part of her brain has been damaged.

[1 mark]

06 . 6

A man has a head injury.

He staggers and sways as he walks.

Suggest which part of his brain has been damaged.

[1 mark]

07

Figure 8 shows an image of a small section of DNA.

Figure 9 shows the structure of a small section of DNA.

Figure 8



Figure 9

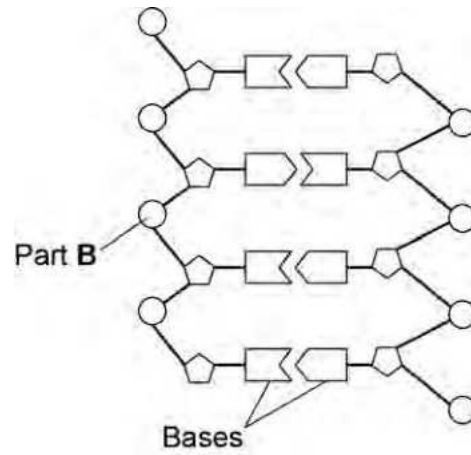

07

. 1

What is Part B?

[1 mark]

07

. 2

In Figure 8 the structure of DNA shows four different bases.

There are four different bases and they always pair up in the same pairs.

Which bases pair up together?

[1 mark]

Question 7 continues on the next page

0	7	.	4
---	---	---	---

A recessive allele causes syndrome H.

A heterozygous woman and a homozygous recessive man want to have a child.

Draw a Punnett square diagram to determine the probability of the child having syndrome H.

Identify any children with syndrome H.

[5 marks]

Use the following symbols:

A = dominant allele

a = recessive allele

Probability = _____

Turn over for the next question

0 | 8

Food security is when a population has enough food to stay healthy.

Lack of food security is a global problem.

One way to maintain food security is to increase the efficiency of food production.

Figure 10 shows how some pigs are farmed using intensive methods.

Figure 10



0 | 8

. 1

Some people think the farming methods shown in Figure 10 are unethical.

Suggest two other possible disadvantages of intensive farming methods.

[2 marks]

1

2

A newspaper reported that:

'Food security is a serious problem in remote communities in Canada. This is because Aboriginal communities are eating fewer traditional foods.'

One traditional food eaten by Aboriginal communities in Canada is seal.

Look at Table 4.

Table 4

Year	Number of seals caught in thousands
2004	362
2005	316
2006	348
2007	224
2008	215
2009	91
2010	67

. Calculate the percentage (%) decrease in the number of seals caught from 2004 to 2010.

[2 marks]

Decrease in seals = _____ %

0	8	.	4
---	---	---	---

The conclusion in the newspaper might not be correct.

Suggest two reasons why.

[2 marks]

1

2

Turn over for the next question

0 9

Homeostasis controls the internal conditions of the body.

0 9 . 1

Explain how blood glucose levels are controlled in the body of someone who does not have diabetes.

[4 marks]

0 9 . 2

Compare how each type of diabetes is caused.

Suggest how each type of diabetes can be treated.

[4 marks]

0 9 . 3 Look at Table 5.

Table 5

Population of UK in 2015	6.5×10^7
Number of people diagnosed with diabetes	$3.45 \times$
Estimated number of people with undiagnosed diabetes	$106 \ 5.49$ $\times 10^5$

Calculate the percentage (%) of the UK population estimated to have diabetes.

You should include both diagnosed and undiagnosed people in your calculation.

Give your answer to 2 significant figures.

[3 marks]

Estimated percentage of population with diabetes = _____ %

Question 9 continues on the next page

0	9	.	4
---	---	---	---

A urine test can be used to check for the presence of glucose in the urine.

Diabetes can also be diagnosed with a blood test to measure the concentration of blood glucose.

Suggest why a blood test is more reliable than a urine test.

[1 mark]

0	9	.	5
---	---	---	---

A blood test called the glucose tolerance test checks how well the body processes glucose.

Concentrations of glucose in the blood are measured before and after drinking a glucose drink.

Patients are not allowed to eat food for 8 hours before the glucose tolerance test.

Suggest why patients are not allowed to eat for 8 hours before the test.

[1 mark]

09 . 6 Figure 11 shows the results of a glucose tolerance test for two patients, A and B.

Figure 11

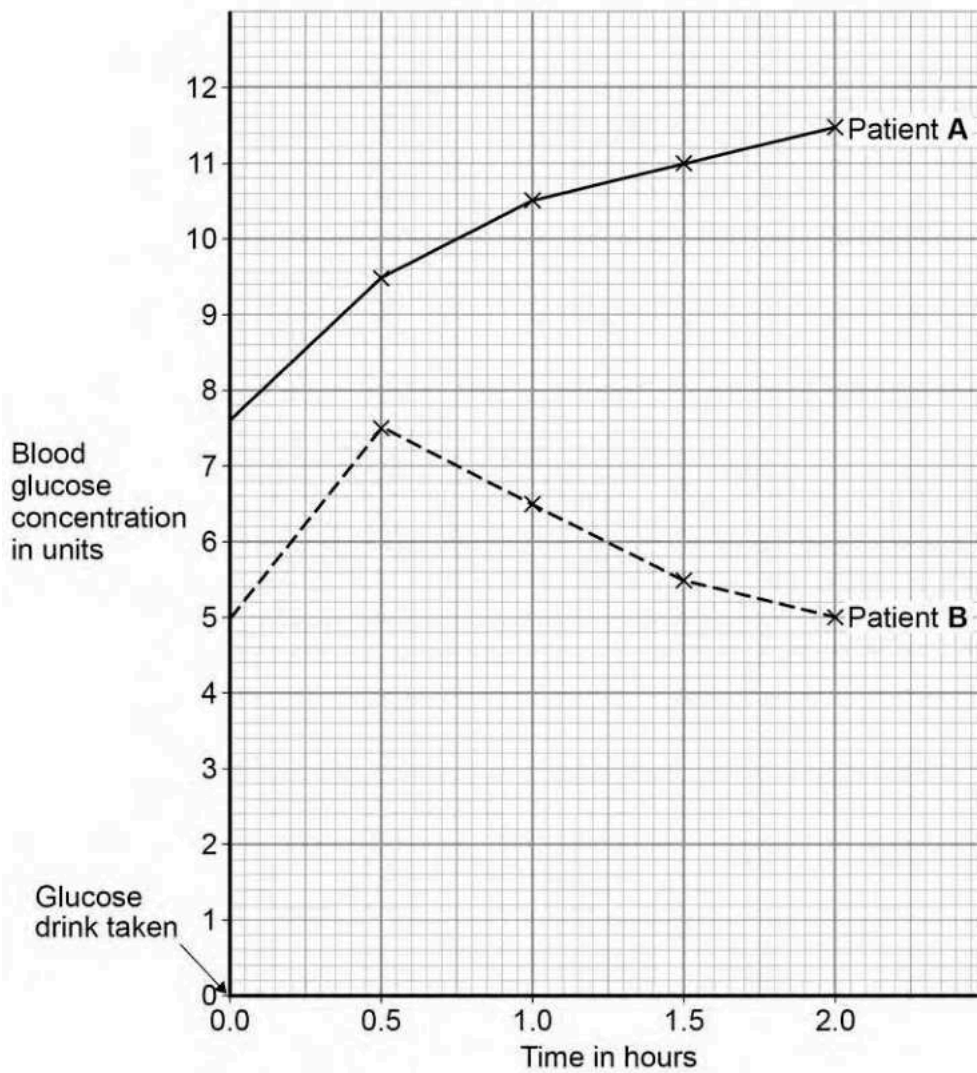

Which patient has diabetes?

Justify your answer.

[2 marks]

Patient _____

Justification _____

1	0
---	---

Endocrine glands produce hormones.

1	0
---	---

1

Hyperthyroidism is caused by an overactive thyroid gland.

Suggest what would happen in the body of a person with hyperthyroidism.

[3 marks]

1	0
---	---

2

Describe the roles of FSH and LH in the menstrual cycle.

[2 marks]

There are no questions printed on this page

Copyright information

Permission to reproduce all copyright material has been applied for. In some cases, efforts to contact copyright-holders may have been unsuccessful and AQA will be happy to rectify any omissions of acknowledgements in future papers if notified. If you have any queries please contact the Copyright Team, AQA, Stag Hill House, Guildford, GU2 7XJ.

Copyright © 2016 AQA and its licensors. All rights reserved.

Figure 1: Fossilised snake © Peter Menzel/Science Photo Library
Table 1: Japanese rat snake © Kazzpix/Thinkstock
Table 1: Texas rat snake © Alexey Kuznetsov/Thinkstock
Figure 2: Decaying strawberry © sarahdoow/Thinkstock
Figure 2: Strawberry © Mariusz Blach/Thinkstock
Figure 4: Dilating iris © Gandee Vasan/Getty Images
Figure 8: DNA computer-generated image © Svisio/Thinkstock
Figure 10: Intensively farmed pigs © Ingram Publishing/Thinkstock